

Operating Manual & Routine Servicing



Hi T 500



Compact Tracked Carrier Mk4 v3



Taylor Construction Plant Ltd.

Quayside INDUSTRIAL Park, Bates Road,
Maldon, Essex, CM9 5FA

Tel: +44 (0)1621 850777

Fax: +44 (0)1621 843330

mail@tcp.eu.com

www.tcp.eu.com

Table Of Contents

Warranty policy and procedures
Sample certificate of conformity

1. INTRODUCTION

Introduction
Safety Precautions
Machine Identifications
Theft Deterrent Practices

2. SAFETY PRECAUTIONS

General
Preventing Fire Hazards
Precaution Electrical Hazard
Pre-Starting
Starting
Operating
Lubrication and Servicing
Decals

3. CONTROLS

Operating Controls Diagram
Accelerator
Steering the Machine
Reversing the Machine

4. OPERATING

Pre Starting Inspection
Component Checks
Engine Operation
Starting the Engine
With Jumper Cables
Battery Charging
Moving and Stopping
Stopping the Engine
Parking
Loading
Tipping
Average Specific Gravity

5. LUBRICATION AND SERVICING

- Safety Precautions
- Lubrication and Servicing
- Miscellaneous Servicing Information
- Recommended Lubricants
- Lubrication Chart
- Overall Size Dimensions (Various)
- Basic Vehicle Details
- Miscellaneous Bolt & Nut Torque Specification
- Every 10 Hours of Operation (Daily)
- Every 50 Hours of Operation
- Every 1,000 Hours of Operation
- Every 2,000 Hours of Operation

6. MAINTENANCE AND REPLACEMENT PARTS

Replacement of Rubber Track
Assemblies and Parts Listings:

- Tracked Carrier Assy
- Chassis Assy – Stage 1
- Chassis Assy – Stage 2
- Chassis Assy – Stage 3
- Chassis Assy – Stage 4
- Chassis Assy – Stage 5
- Engine Enclosure Assy
- Decal Assy
- Battery Box Assy
- Engine Dressing Assy
- Engine Service Kit
- Hydraulic Cooler Assy
- Cold Start Assy
- Electrical Schematic
- Engine Loom Assy - 1
- Engine Loom Assy - 2
- 2 Speed Loom Assy
- Auxiliaries Loom Assy
- Cold Start Loom Assy
- Battery Leads
- Hydraulic Schematic
- Hoses and Fittings Assy - 1
- Hoses and Fittings Assy - 2
- Hydraulic Tank Assy
- Control Valve Assy
- Chassis Sound Kit Assy
- Enclosure Sound Kit Assy

Warranty Policy and Procedures

Foreword

Thank you very much for purchasing this TAYLOR or CONSTRUCTION PLANT Ltd product. We believe that it will serve you without fail. Ensure that you read the Operator's Manual carefully before use. With proper handling and maintenance, this TAYLOR CONSTRUCTION PLANT Ltd product will provide excellent service over an extended period of time.

Registration

Each machine supplied by TAYLOR CONSTRUCTION PLANT Ltd is accompanied by a registration card. This card must be completed in full and returned to:

Warranty Manager (email: warranty@tcp.eu.com)

Taylor Construction Plant Ltd.

Quayside Industrial Park

Bates Road

Maldon

Essex, CM9 5FA

Failure to register your machine may invalidate the manufacturer's warranty.

Liability

The warranty period begins when the product is delivered to and installed at the first purchaser. Only genuine parts may be used to carry out repairs. Failure to use only genuine parts may invalidate the Manufacturers Warranty.

TAYLOR CONSTRUCTION PLANT Ltd will not be held responsible if:

- (i) the machine has been used to perform tasks that demand more than it's design and strength limitations, or
- (ii) the machine has undergone modifications not approved by TAYLOR CONSTRUCTION PLANT Ltd, or
- (iii) conditions of use have been abnormal, or
- (iv) normal maintenance, with regard to requirements as set out and detailed by the manufacturer, have not been adhered to.

TAYLOR CONSTRUCTION PLANT Ltd will not pay for normal maintenance or servicing nor any materials used to carry out routine servicing.

The warranty liability of TAYLOR CONSTRUCTION PLANT Ltd is limited to diagnosis, repair or replacement of the defective part, and actuating the repair - depending on the product terms and conditions, this will be free of charge.

TAYLOR CONSTRUCTION PLANT Ltd shall be under no liability whatever to the customer for any indirect loss and/or expense (including loss of profit) suffered by the customer arising out of a breach by TAYLOR CONSTRUCTION PLANT Ltd of this contract.

Warranty Audits and Surveys

TAYLOR CONSTRUCTION PLANT Ltd reserves the right to carry out audits and inspections from time to time in relation to any reimbursed or outstanding warranty claims in order to determine that all relevant details and information is correct.

Service and Warranty Training

Service and warranty training for service fitters can be requested in writing. Initial training is to be carried out at an appropriate TAYLOR CONSTRUCTION PLANT Ltd workshop. Once this initial training has been carried out, you are responsible to carry further training as required by your own service centre or depot network.

Service Bulletins

TAYLOR CONSTRUCTION PLANT Ltd may from time to time issue service bulletins to keep you up to date as to any improvements or changes that may take place on the complete assembly or component parts.

Warranty Terms for Machines

Model	Terms
TAYLOR CONSTRUCTION PLANT Hi-T500 tracked dumper	One year or 1000 hours whichever occurs first from date of installation
TAYLOR CONSTRUCTION PLANT Hi-C40 mobile crusher	One year or 1000 hours whichever occurs first from date of installation

ALL ENGINE WARRANTY ISSUES MUST BE DIRECTED TO THE ENGINE MANUFACTURER, OR THE MANUFACTURERS APPROVED/APPOINTED ENGINE DEALER.

General Exclusions:

THE FOLLOWING ARE WARRANTY EXCLUSIONS AS DETERMINED BY KUBOTA:
Service items including lubricants, coolants, filters, glow plugs, fan belts, fuel injection equipment, stop solenoid/relay, charge regulator, leaks (oil, water and air).

IN ADDITION: paintwork, wear parts and tracks.

Warranty Claim Submission Procedures

Claims must be reported accurately and all relevant details given, as follows:

OWNERS NAME AND ADDRESS: full name and address of customer and site location, if different

MACHINE TYPE: State machine type, i.e. Hi-T500, tracked dumper, Hi-C40, crusher

DATE OF FAILURE:

INSTALLATION DATE: The actual date of installation, not invoice date

SERIAL NUMBER: Serial number of unit

ENGINE NUMBER: Serial number of engine

HOURS USED: State hours used on hour clock. Please do not guess the hours used

DETAILS OF FAILURE: Give a full report on the failure

ORDER NUMBER: An order number **will** be required

Note: the order number is to cover the diagnostic and call out time, as well as to determine the following:

(i) That the failure is to be covered under the terms and conditions of warranty. If this is the case, then the costs will be covered by TAYLOR CONSTRUCTION PLANT Ltd and the **order number will not be used**.

(ii) If the failure is determined to be of a non-warrantable nature, further authorisation to continue will be sought before any rectification work takes place.

The information above must be provided even if your warranty claim is a “parts only” claim. An invoice will be raised for the exchange parts. The reported faulty/defective part must immediately be returned to TAYLOR CONSTRUCTION PLANT Ltd and full inspection of the parts carried out, if the failure is covered under the terms and conditions of warranty a credit note corresponding to the invoice will be despatched to the customer. If the failure is deemed to be of a non-warrantable nature, the invoice should be settled immediately.

Kubota UK Engine Dealers:

Bryce Group Ltd.

Daimler Close, Royal Oak Industrial Estate, Daventry, Northants NN11 5QJ.

Tel:- 01327- 876166 Fax :- 01327- 300244

admin@bryco-diesel-engines.co.uk www.bryco-diesel-engines.co.uk

C.M.H. LTD.

Maudlins Industrial Estate, Monread Road, Naas, Co Kildare, Eire.

Tel :- 00-353-458-76225 Fax :- 00353-459-7476

cmhltd@gofree.indigo.ireland

Hurley Engine Services.

Unit 7, The Maltings Industrial Estate, Brassmill Lane, Bath, Somerset, BA1 3JL.

Tel :- 01225-336812 Fax :- 01225-442477

info@hurleyengines.co.uk

Bryco Group Ltd.

Daimler Close, Royal Oak Industrial Estate, Daventry, Northants. NN11 5QJ.
Tel:- 01327- 876166 Fax :- 01327- 300244
admin@bryco-diesel-engines.co.uk www.bryco-diesel-engines.co.uk

C.M.H. LTD.

Maudlins Industrial Estate, Monread Road, Naas, Co Kildare, Eire.
Tel :- 00-353-458-76225 Fax :- 00353-458-97476
cmhltd@gofree.indigo.ireland

Hurley Engine Services.

Unit 7, The Maltings Industrial Estate, Brassmill Lane, Bath, Somerset. BA1 3JL.
Tel :- 01225-336812 Fax :- 01225-442477
info@hurleyengines.co.uk www.hurletengines.co.uk

Jem Engines

23 Polmont Road, Laurieston, Falkirk, FK2 9QQ.
Tel :- 01324-633266 Fax :- 01324-633870
info@jemengines.com www.jemengines.com

Meetens Industrial Engines Ltd.

Unit 2 Eclipse Trading Estate, 30 West Hill, Epsom, Surrey. KT19 8JD
Tel :- 0845-6340296 Fax :- 0800-0150707.
sales@meetens.com www.meetens.com

Northern Lift Trucks (Northern Ireland) Ltd.

1 Flush Park, Knockmore Road, Lisburn, BT28 2DX.
Tel :- 02892-673111 Fax :- 02892-660618
info@northern-group.co.uk

Phoenix Power Services.

Unit 12, Thames Trading Centre, Woodrow Way, Irlam, Manchester. M44 6BP.
Tel :- 0161-775-4053 Fax :- 0161-776-2047.
phoenixpower@btclick.com

Sean Cleary & Son Eng.Ltd. I.D.A. Industrial Estate, Dublin Road, Loughrea, Co.Galway, Eire.

Tel :- 00-353-91-841420 Fax :- 00-353-91-842823
paddyCleary@eircom.net

Trucks Morley Ltd.

Wakefield Road, Morley, Leeds. LS27 0JZ
Tel :- 0113-2526777 Fax :- 0113-2380310.
trucksmorley@tiscali.co.uk

Universal Engine Power Ltd.

Unit 9, Fritch Industrial Estate, Chelmsford Road, Great Dunmow, Essex. CM6 1XJ.
Tel :- 01371-875331 Fax :- 0871-222-3772
info@uni-power.co.uk www.uni-power.co.uk

Woodleigh Power Ltd.

Unit 20, Highcroft Industrial Estate, Enterprise Road Horndean, Waterlooville, Hants. PO8 0BT.
Tel :- 02392-571360 Fax :- 02392-592056.
sales@woodleighpower.co.uk www.woodleighpower.co.uk

Yardbury Kinetics Ltd.

Altens Trade Centre, Hareness Circle, Aberdeen. AB12 3LY
Tel :- 01224-897947 Fax :- 01224-872374
admin@yardburykinetics.co www.yardbury.com

CERTIFICATE OF CONFORMITY

We declare that this product complies with the following Standards/Directives.

Machinery Directive 89/392/EEC as implemented by The Supply of Machinery (Safety) Regulations 1992 (Amended 1994).

BS/EN500 Mobile road construction machinery (Safety)

Product	:Tracked Carrier
Model	:HiT 500
Serial No	:HT-Bxxxx
Manufacturer Date	:xx/xx/2006

Signed: *PDrew*

Date: xx/xx/2006

Mr Paul Drew
Development Manager

This is a sample certificate of conformity inserted in this manual for reference, each machine is issued with a bespoke certificate sent to the head office of the purchaser, and copies are available on the request of purchaser.

1. Introduction

Please read carefully and understand before operating the equipment.

This Handbook is provided as a guide to familiarise the operator and service engineer with the controls, recommended inspections, start-up, operating, and shutdown procedures for HiT range of equipment.

Safety Precautions

*This piece of equipment is designed as a compact tracked carrier with the carrying capacity of 500 Kg only.
At all times loads should be carried with the body in the low position and raised for tipping only when the unit is stationary*

**FAILURE TO COMPLY WITH WARNINGS COULD RESULT
IN SERIOUS PROPERTY DAMAGE AND POSSIBLE
PERSONAL INJURY.**

The machine should be properly operated and maintained to keep it in safe efficient operating condition. Be sure that all controls are free of mud, grease, or other matter that might cause slips hazardous to the operator, serviceman, or other personnel or equipment.

Report all malfunctions to those responsible for maintenance. Do not operate the equipment until corrected. Normal service or maintenance performed as required can prevent unexpected and unnecessary down time. This handbook describes general inspections, servicing and operation with the normal safety precautions required for normal servicing and operating conditions. It is not a guide however, for other than normal conditions or situations.

Operators and Servicemen must be safety conscious and alert to recognise potential operating or servicing safety hazards at all times, and take, necessary precautions to ensure safe operation and servicing of the machine.

All information, illustrations and specifications contained in this publication are based on the latest product information available at the time of publication. The right is reserved to make changes at any time without notice

Continuing improvement and advancement of the design may cause changes to your machine that may not be included in this publication.

This Handbook contains lubrication and routine servicing instructions, most of which can be performed in the field. Service manual containing repair and rebuild procedures are available from the factory.

Machine Identification

Whilst reading this handbook you will notice references to controls and equipment that may not be found on all machines. It is important that you know your machine and its equipment and how to operate it properly.

Information regarding the machine model, code and chassis serial number is on the unit serial number plate. This plate is on the rear Left-hand side the machine model and serial number should always be referenced in any correspondence with your dealer or factory.

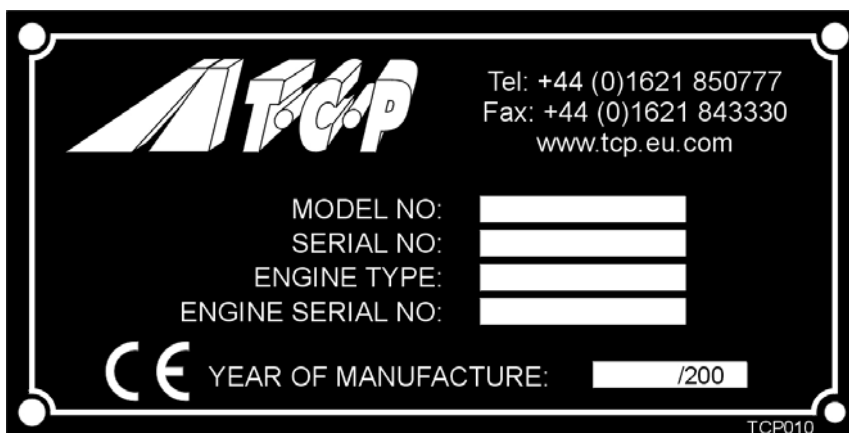

Data Plate (Fig. 1)

Theft Deterrent Practices

The owner/operator should take the following precautions to discourage theft, to aid in recovery in the event that the machine is stolen, or to reduce vandalism.

Actions to Discourage Theft and vandalism

- Remove all keys any time the machine is left unattended.
- Immobilise the machine by removing a critical electrical or starting system device.
- Upon receipt of a machine, record the machine serial number and the serial numbers of all-major components and attachments. Keep this list up to date and filed in a safe location for fast retrieval.
- Place a decal or notice on the machine stating that all serial numbers are recorded.
- Discourage the thief! Inspect the gates and fences of the machinery storage yard or construction site. Keep machines in well-lit areas and ask the local law enforcement authorities to make frequent checks around the storage yard or work site.
- Establish liaison with neighbours and ask them to watch equipment left at job sites and to report any suspicious activities to local law enforcement authorities.
- Make frequent inventories of machines to promptly detect losses or vandalism.

Actions to aid in recovery of stolen machines

In the event of theft, immediately notify the law enforcement authorities having jurisdiction. Provide the investigating officer with name, type of equipment, chassis and serial numbers of major attachments and components. It would be helpful to show the investigating officer an Operator's Handbook, photographs, and advertising, to familiarise him with the appearance of the machine.

Report the theft to the insurance company. Provide the model and all serial numbers.

Report the model and serial numbers of the stolen machine to a dealer handling the respective line of equipment. Request that the dealer forward this same information to the equipment manufacturer.

2. Safety Precautions

General



- Read this operator's Handbook and learn the operating characteristics and limitations of the machine. Know what operating clearances the machine requires.
- Know clearances of all side and overhead obstructions such as wires, etc., for operating safety.
- Be aware of operating hazards that weather changes can create on the job. Know proper procedures to follow when a severe rain or electrical storm strikes.
- Never attempt to operate or work on a machine when not feeling physically fit.
- Know what safety equipment is required and use it. Such equipment may be hardhat, safety glasses, reflector type vests, respirators and earplugs.
- Never wear loose clothing, rings, and watches etc. that might catch levers and controls and cause loss of control.
- Keep hand controls free from water, grease and mud to assure non-slip control.
- Handle fuels and lubricants carefully and clean up spills to avoid fire and slipping hazards.
- Never rush. Walk do not run.

Preventing Fire Hazards



General Fire Precautions

- Clean all dirt, oil, grease and other fluids from systems and components to minimise fire hazards and aid in spotting loose or leaking lines, fittings etc.
- Check the engine for rubbish, oily rags or other debris that could cause fires before starting the engine.
- Safely dispose of greasy, oily rags or similar hazards.
- Flammable Fluid Precautions
- Don't use diesel fuel or other flammable fluids for cleaning purposes. Use approved non-flammable solvents.
- Make sure all-fluid systems caps, drain, valves, fittings, lines etc., are secure and leak free.
- Never use an open flame (match, lighter etc.) when checking fuel, lubricant, coolant and battery fluid levels or when checking for fluid leaks. Use a flashlight or other safe lighting only.
- Shut off engine and use extra caution if engine is hot when refuelling. Never smoke while checking or adding fuel or other fluid or handling fluid containers and lines.
- Use care and do not stand downwind when adding fuel or other flammable fluids to tanks and reservoirs to avoid fluids being blown or splashed onto clothing.
- Close fuel tank shut-off valves, if used, before servicing fuel system.
- When preparing machines or components for storage, seal and tape all openings and close containers tightly to seal in all volatile inhibitor fluids and compounds used.
- Follow manufacturer's recommendations when handling and using engine-starting fluids and disposing of spent containers. Do not puncture or burn empty containers. These fluids are explosive and highly flammable.

Precautions Electrical Hazard.



- Never smoke or allow open flames or sparks near batteries.
- Leave battery box open when charging batteries in machine for adequate ventilation of explosive gas (Hydrogen) produced.
- Always disconnect batteries before repairing electrical system to avoid danger of fire-causing sparks. Disconnect battery ground cable first and reconnect last.
- Always disconnect batteries and alternator leads before carrying out any welding on the machine.
- Never check battery charge by placing metal objects across battery posts to avoid sparks at battery posts.
- Use jumper cables only as recommended. Improper use can result in battery explosion or unexpected machine motion.
- Never operate engine starter for more than 15 seconds and allow 30 seconds between cranking periods for cooling. An overheated starter could cause a fire.

Pre-Starting



- If engine is to be started and run indoors, ensure proper ventilation to remove deadly exhaust gases.
- Always perform 'Pre-Starting Inspection' instructions described in this manual to ensure the machine is ready for operation.

Starting



- Do not start the engine or operate any control if there is a 'DO NOT OPERATE' or similar warning sign attached to any control.
- Use jumper cables only as recommended. Improper use can result in battery explosion or unexpected machine motion.

- Always obey 'Starting the Engine' instructions.
- Start and operate the machine **only** from the operator's station.

Operating



- Always perform 'Pre-Operating Checks' described in this manual to ensure the machine is ready for operating.
- Do not operate the machine if exposed personnel enter the immediate work area.
- Be sure the body is fully down before moving the machine-warning buzzer will sound if body is not fully down.
- Always try to face or look in the direction the machine is travelling.
- Always operate straight up or down slopes whenever possible. Side-hill operation can cause sideslip and possible rollover.
- Slow down when moving in congested areas. Do not race with other machines. Stop in authorised areas only, except in an emergency.
- Always watch for holes, soft edges or other hazards when dumping over a spoil bank.
- Operate body raising mechanism on firm level surface only, a buzzer will sound to warn the operator and others in the area once the body raises above horizontal.

Lubrication and Servicing



- Do not allow unauthorised personnel to service or maintain the machine. Study the Operator's handbook and Service Manual before starting, operating or servicing the machine.
- Do not work under or near unblocked or unsupported body. Always invert the empty body.
- Do not work under or near any unblocked or unsupported linkage, part or machine.
- Always relieve pressure before servicing any pressurised system.

Decals

Decals fitted to machines may vary from country to country to suit local needs. These pages contain a brief description and the location of the decals and control plates that may appear on this machine.

Ref	Part Number	Part Name	Qty
1	80-0076	Control Panel Mk4	1
2	80-0001	Data Plate – Serial No.	1
3	80-0077	Muffler	6
4	80-0004	Warning Hot Exhaust	2
5	80-0012	Oil Filter & Dipstick	1
6	80-0005	Oil Filler	1
7	80-0010	H T 500 Body Logo	2
8	80-0003	Warning Crush Zone	6
9	80-0013	Caution Sign	1
10	80-0020	Starting Instructions	1
11	80-0009	Warning Crush Zone	2
12	80-0007	'CE' Marking	2
12	80-0011	PTO Optional	1

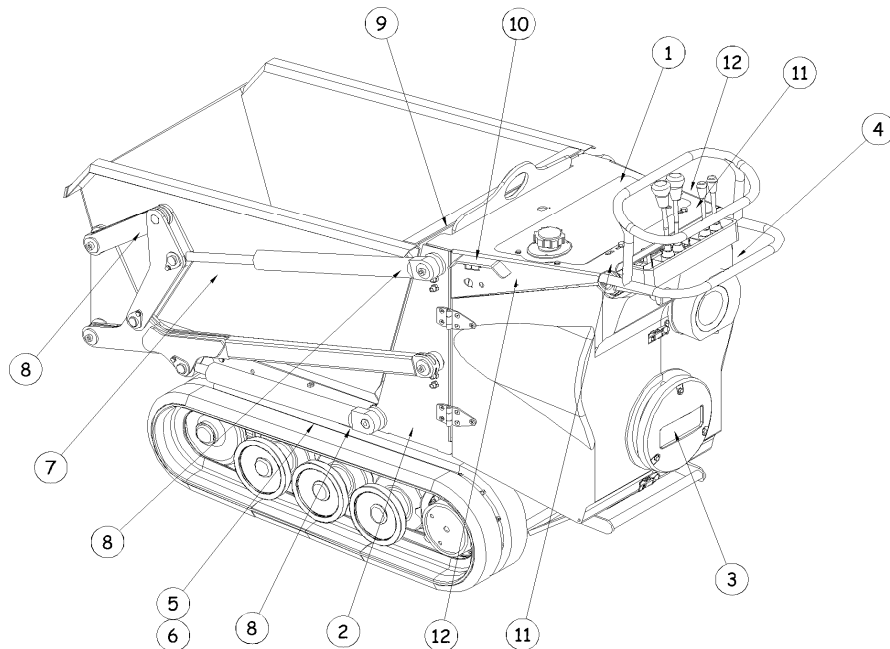

Decal Layout (Fig. 2)

3. Controls

Operating Control Diagram

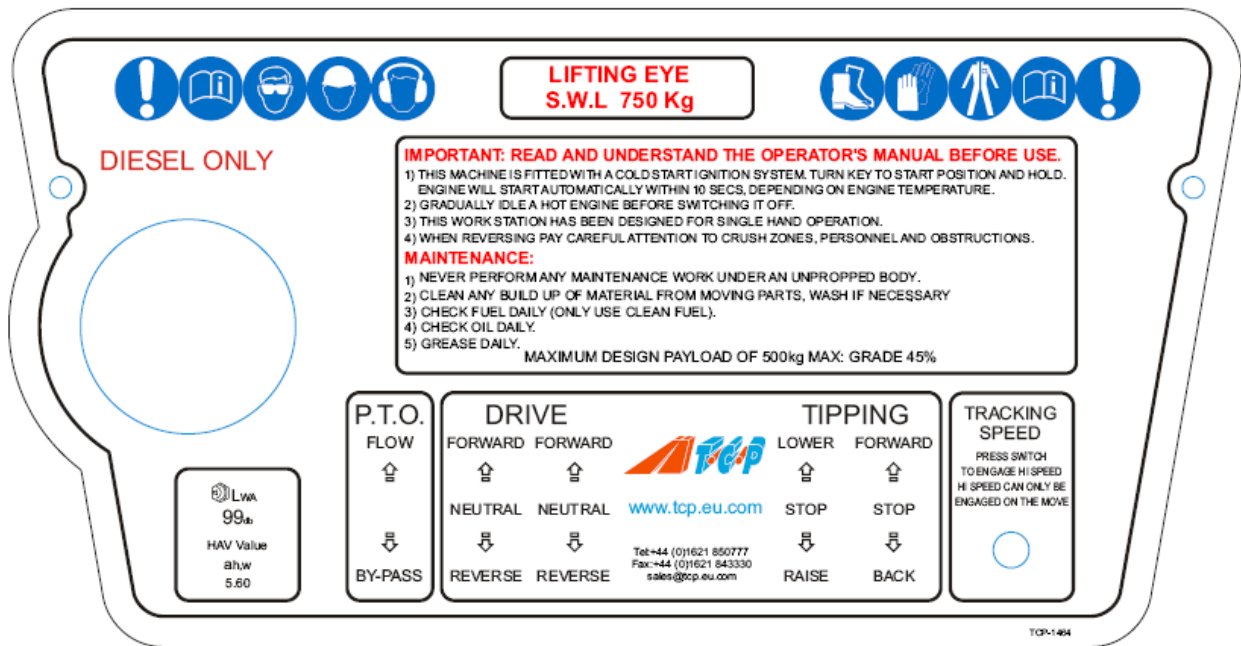

A view of the Control Panel (fig 3)

Engine Accelerator

This is mounted on the left-hand side of handlebar assembly and is operated by the hand. Press the lever down as required to increase fuel flow to accelerate the engine.

Do not place engine under full load at full speed immediately after starting. Always allow the engine to fully circulate lubricant and warm up gradually before operating at full speed and full load. Operate the engine at top rated speed when maximum power is needed for maximum speed and load.

Steering Via Hydrostatic Drive

The steering is performed by:



- To steer the machine, apply differing pressure to the control levers.
- Apply equal pressure on both levers to the forward position will make the machine move forward in the desired direction at speed.
- The machine will turn only when more or less pressure is applied to either lever proportional to the lever movement

To operate in the opposite direction.

The Reverse procedure is performed by:



- Apply equal pressure on both levers to the reverse position will make the machine move backward in the desired direction at speed.
 - The machine will stop and hold any position when the both levers are released (Dead-man Brake)

4. Operating

Operating

Pre-starting Inspection



- Before the engine is started ensure the machine is ready for operation
- The machine should be in a level position to permit accurate checking of fluid quantities in the engine and other components.
- Walk around the machine and carry out the Inspections and Components Checks described on the following pages.

Daily Component Checks

ACCESS TO THE ENGINE FOR ROUTINE MAINTENANCE IS ACHIEVED BY OPENING THE LEFT HAND SIDE OF THE ENGINE ENCLOSURE.

- Reference should be made to engine manufactures handbook.
- Engine - With engine off, check oil level. The level should be just over the last thread at filler Add oil if low. (See lubricant chart for correct oil).
- Inspect the engine air cleaner for any damage (replace immediately. Using an engine with a damaged air cleaner will seriously reduce engine life).
- Check that oil cooler outlet grill (between body and chassis) is clear of obstructions.

THESE INSTRUCTIONS MUST BE ADHERED TO IN ORDER TO ASSURE CONTINUANCE OF ENGINES WARRANTY.

- Carefully inspect tracks for cuts, or other damage, and correct spring preload.
- Inspect for any leaks whether fuel, engine oil or hydraulic oil.
- Check fuel level - Fuel tank should be filled at end of each shift.

Engine Operation



Do not place engine under **FULL LOAD** at **FULL SPEED IMMEDIATELY** after starting. **ALWAYS** allow the engine to fully circulate lubricant and warm up gradually before operating at full speed and full load.

Operate engine at top rated speed when maximum power is needed for the load.

***NEVER IDLE THE ENGINE FOR MORE THAN 5 MINUTES AT A TIME.
SHUT IT OFF.***

If operated outside its normal operating range, shut engine down immediately and report to service or maintenance personnel.

WARNING

Never start the engine indoors unless proper exhaust ventilation is provided to remove deadly exhaust gases. Once the engine is running, move the machine outdoors as soon as possible. Exhaust gases are hazardous and can cause unconsciousness and death.

Operating the engine beyond high idle speed can cause severe engine damage. The engine speed must not exceed 3,600 rev/min under any circumstances. When descending a steep grade, use a combination of lever and engine speed.

Starting the Engine

The Mk4 is fitted with a start delay circuit to allow the glow-plug to reach its operating temperature before the engine will crank, this is operative at all times.

1. Make sure that all levers are in the neutral position.
2. Insert switch key and turn fully clockwise to position '3' and hold, the engine will crank automatically after approximately 5 seconds, release key.

NOTE:

**Never crank the engine for more than 10 seconds continuously.
Allow starter at least 30 seconds cooling time between cranking periods to avoid overheating.**

Starting the Engine with Jumper Cables.

Access to the battery and starter motor terminals is restricted on the Mk4. To allow jump starting to take place a Stud Terminal is located on the left rear of the engine mounting frame, this Stud Terminal is connected to the positive stud on the battery. To access this Stud Terminal open the left hand side of the engine enclosure.

WARNING CHARGING OF ODYSSEY BATTERIES

Check for polarity connections of the discharged battery.

Do not exceed 15 volts during charge. Excessive booster voltage and/or incorrect jumper cable connections will destroy working plates inside battery. Keep all sources of ignition away from batteries. Do not lean over batteries.

Do not allow the battery to become full discharged you may find that it can not be recover from this state rendering it unserviceable

Voltmeter Reading	State of charge
12.84 Volts	100%
12.50 Volts	75%
12.18 Volts	50%
11.88 Volts	25%

Do not jump start a vehicle by using arc welding equipment. Currents and voltages are dangerously high and cannot be sufficiently reduced to make the method safe.

NOTE:

Be sure machines are not touching each other. Use cables that are equal to cable size on the machine.

If jumper cables are used to start an engine, be sure to follow this procedure:

Connect one end of the jumper cable, usually coloured red, to the discharged battery '**POSITIVE**' (+) stud terminal.

Connect the other end of the same cable to the '**POSITIVE**' (+) post on the booster or charged battery.

Connect one end of the second cable, usually coloured black to the '**NEGATIVE**' (-) post of the booster battery.

Connect one end of the jumper cable to a convenient point on the engine frame '**NEGATIVE**' (-).

Keep grounding point clear of battery so that if a spark occurs, it is away from battery fumes (explosive hydrogen).

Check for cause of failure on the dead battery.

Battery Charging

A battery charging connection socket is built into the Mk4 and is located on the left hand side of the Battery Box, near to the engine mounting frame. Access to this is gained by opening the left hand enclosure panel. The connection point is designed to be used with a **Coulombi Charger** (TCP Part No. 82-0004).

**UNDER NO CIRCUMSTANCES SHOULD THIS CONNECTOR
BE USED TO JUMP START THE MACHINE.**

Moving and Stopping



1. Make sure the area around the machine is clear of personnel and obstructions before moving off.
2. In the first few minutes of travel check carefully for the required controls for maximum operating safety.
3. Make sure the body is fully down, buzzer will sound if in the raised position.
4. Select the driving direction and the required engine speed.
5. Move levers to the required position; apply more accelerator until the required speed has been reached.
6. To stop the machine release the control levers slowly and release the accelerator as the machine slows until it stops.

Stopping the Engine



1. Cool a hot engine by operating the engine at 1,000 rev/min and then slowly decelerating it over a 5-minute period until the engine is idling. Let it idle for at least 2 minutes.
2. **ALWAYS COOL A HOT ENGINE GRADUALLY BEFORE SHUTTING IT OFF.**
3. Turn ignition key switch off to shut off fuel and stop engine.
4. Make sure body is in the lower position.

Parking



When parking the machine overnight, or for an extended period, the following procedure in addition to that given in ‘**Stopping the Engine**’ will help maintain it in good condition for subsequent use:

1. Fill the fuel tank completely before parking the machine overnight or for extended periods, to prevent condensation. If security kit is supplied, keep it locked
2. Always park on level ground where possible. If it must be parked on a slope, position machine at right angles to the slope and block tracks securely.
3. Remove key to a place of safety

WARNING

Check tracks, hoses, wiring, tubing and fittings for cuts, abrasion, fraying, or other damage or deterioration. Inspect for damage to the body or chassis. Attach warning signs to the controls to alert others if lubricant has been drained, batteries removed etc.

Loading

The most common methods of loading this type of machine is with hydraulic excavators, or by hand, these units can be loaded equally well from the front or the side. Ideally, excavators should require 90° or less swing.

Always position the machine on a level firm surface for loading and leave the loading area until indicated by loader driver.

The following precautions should be observed when approaching the loading area and while being loaded wait until it is safe to return to the machine.

Avoid over filling the dump body. Spillage could damage the tracks and other components. Clear up such debris (see fig 4).

Do not load with machines that are over large and would allow material and fill to fall from the bucket missing the body. This can be dangerous to both operator and the unit.

Pay attention to site conditions to avoid rocks, holes, or other obstacles. Such obstacles present hazards to safe operation, but also can needlessly damage tracks.

Tipping



The tipping operation usually depends on the type of material being hauled. Be aware of other personnel within the operating area.

A warning buzzer sounds whenever the body is raised above the horizontal position, this is as a general warning to the operators and other personnel in the operators' zone to take necessary care and precautions.

If tipping at low level, ensure you are clear of all obstacles within the tipping arc of the body. It is possible to fully invert the body of the Hi-T tracked carrier, care must be taken that the load to be discharged will readily leave the body once tipping commences. A retained load may result in machine instability.

Never leave a machine loaded over night, or load with a material that could settle with the engine ticking over for a long period.

Always clean the body of any retained load for efficient safe working.

Be aware of any precautions and additional safety equipment that may be needed when handling, hazardous, caustic or cementitious materials.

If in doubt seek advice.

Before discharging the load, the machine must be on firm level ground.

If one track is higher than the other, a twisting strain is imposed upon the body hinge pins and chassis. This could result in machine instability and damage.

Use the control levers to position the body. Operate from the designed operating position only, keep clear of the tipping mechanism injury could occur. Once the load has been tipped, move the control levers into the 'DOWN' position.

If the load does not clear completely, the built in stops in the mechanism may be used to assist discharge, the cylinder does not need to be retracted before extending again.

To tip into a waste skip choose a position that will allow the body to fully discharge its load, raise the body only with the machine stationary, once raised the machine may be inched forward until the tracks contact the side of the waste skip. The body can then be tipped to discharge load.

Average Specific Gravity

Material	Loose Density		Fill Factor %
	kg/m^3	Ib/yd^3	
Snow (Fresh)	200	337	100
Peat (Dry);	400	674	100
Sugar beet	530	894	100
Coke (Loose)	570	961	85
Barley	600	1012	85
Petroleum Coke	680	1146	85
Wheat	730	1231	85
Coal Bituminous	765	1290	100
Fertilizer (Mixed)	1030	1737	85
Coal Anthracite	1046	1764	100
Earth (Dry)(Loose)	1150	1939	100
Nitrate Fertilizer	1250	2180	85
Sodium Chloride (Dry)(Salt)	1300	2192	85
Cement Portland	1440	2428	100
Limestone (Crushed)	1530	2580	100
Sand (Dry)	1550	2613	100
Asphalt	1600	2698	100
Gravel (Dry)	1650	2782	85
Clay (Wet)	1680	2832	110
Sand (Wet)	1890	3187	110
Fire Clay	2080	3507	100
Ready Mixed Concrete	2194	3698	85
Copper (Concentrate)	2300	3878	85
Slate	2800	4721	100
Magnetite	3204	5402	100

Specific Gravity (Fig. 4)

5. Lubrication and Servicing

SAFETY PRECAUTIONS

- Do not allow unauthorised personnel to service or maintain this machine.
- Study the Operator's Handbook and Service Manual before starting, operating or servicing this machine. Always follow procedures and safety precautions detailed in this manual.
- Do not work under or near an unblocked or unsupported body. Always invert the empty body.
- Do not work under or near any unblocked or unsupported linkage, or any part of machine.
- Always shut down machine according to the procedure described under 'Stopping The Engine' before cleaning, lubricating or servicing the machine
- Always relieve pressure before servicing any pressurisation system.
- Always attach a '**DO NOT OPERATE**' or similar warning sign to ignition switch or a control before cleaning or servicing the machine.
- Use correct 'Personal Protection Equipment' when handling the Ceramic wrapped exhaust pipe and engine cover Ceramic heat barrier.

LUBRICATION AND SERVICING

ACCESS TO THE ENGINE FOR ROUTINE MAINTENANCE IS ACHIEVED BY OPENING THE LEFT HAND SIDE OF THE ENGINE ENCLOSURE.

- Lubrication is an essential part of preventive maintenance. It is important that the instructions regarding types of lubricants and the frequency of their application be followed to prolong the useful life of the machine. Periodic lubrications of moving parts reduce to a minimum the possibility of mechanical failures.
- Thoroughly clean all fittings, caps, plugs etc., to prevent dirt from entering the system while servicing.
- Lubricants must be at operating temperatures when draining.

- Do not operate any system unless oil level is within the operating range as indicated on the dipstick, or level plug.
- All change and service periods are recommendations based on average operating conditions. Lubricants showing evidence of excessive heat, oxidation or dirt should be changed more frequently to prevent these conditions. Lubricants change and service periods must be established on the basis of individual job conditions.

Miscellaneous Servicing Information

When required:

- Hydraulic Tank - Cold Oil Level
- Hydraulic oil dipstick is not used to checked oil it is there to allow the air in the tank to be displaced when filling.
- To add oil, remove red top of filter, pull out filter, and remove dipstick, if low fill through the filter housing until the level is 6mm below the tube in the base of the filter housing.

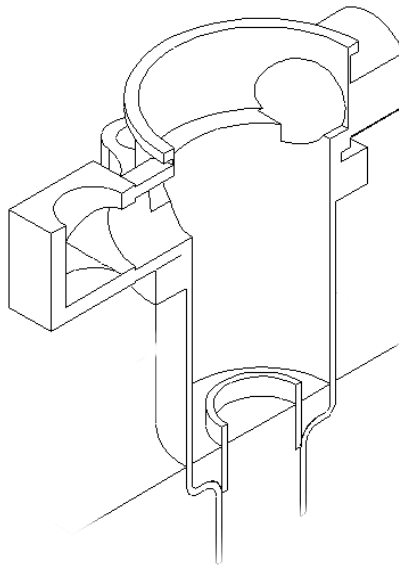

Recommended Lubricants

Note: **Do not mix Lubricants**

Item No	Component	Lubricant	Specifications	API Code	SAE Grade
1	Engine Crankcase and Filter	Engine Oil with 1.85% max. Sulphated ash limit		CC/CD	10W-30
2	Hydraulic System	Hydraulic oil	ISO HV32 Viscosity Index 170		
3	Fuel tank	Diesel Fuel Oil with max. Sulphur 0.5%	A.S.T.M. No.2 Diesel Fuel at sub zero temp. blend No. 2 with No.1		
4	Grease Nipples	Extreme Pressure Lithium (No 'Moly')	Stern Tube Grease C/W Extreme Pressure Capabilities		No. 2 Consistency
4	Hydraulic Motor Gearbox	Gear Oil	Viscosity Index 154		EP220

Lubrication Chart (Fig. 5)

N.B. Shown with Engine Enclosure removed.

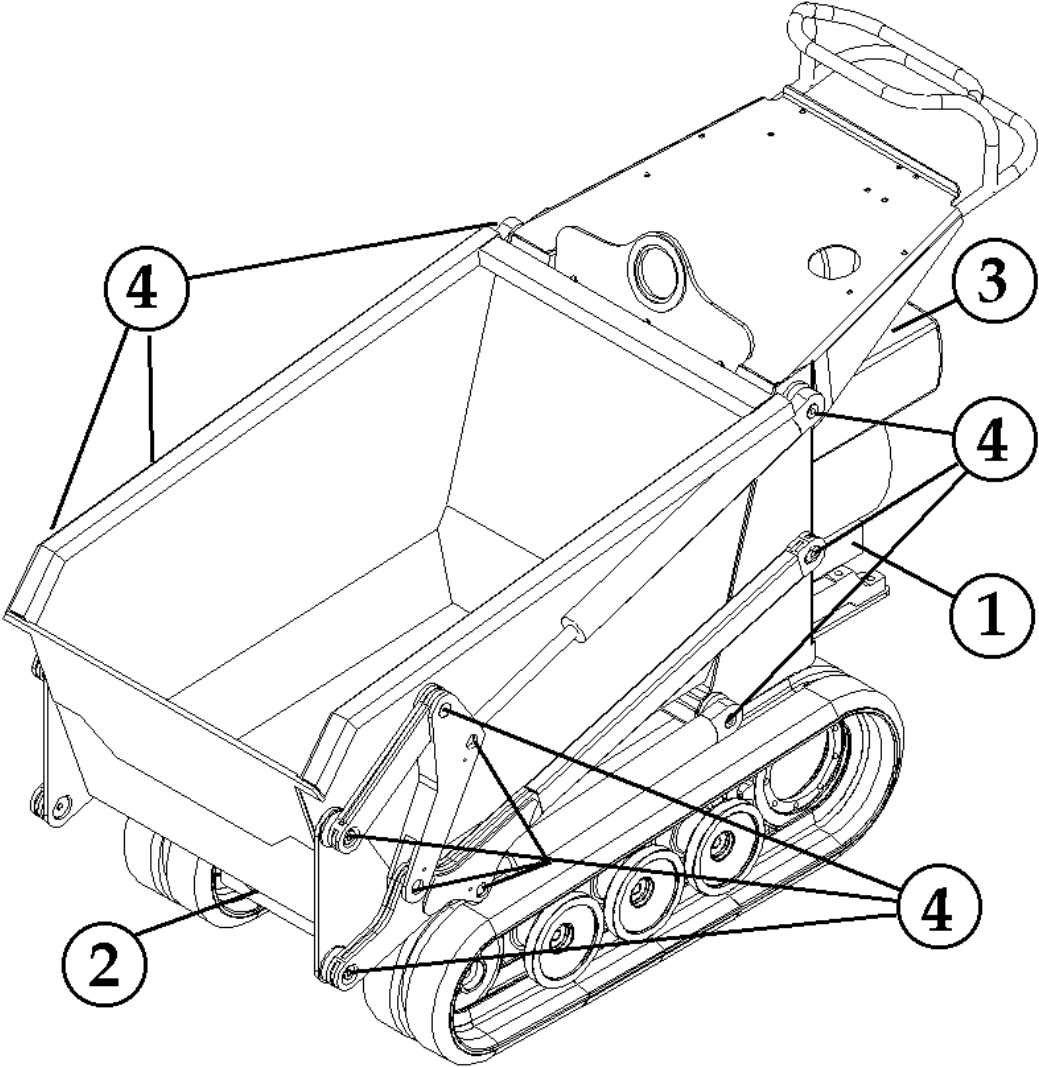

Lubrication Layout (Fig. 6)

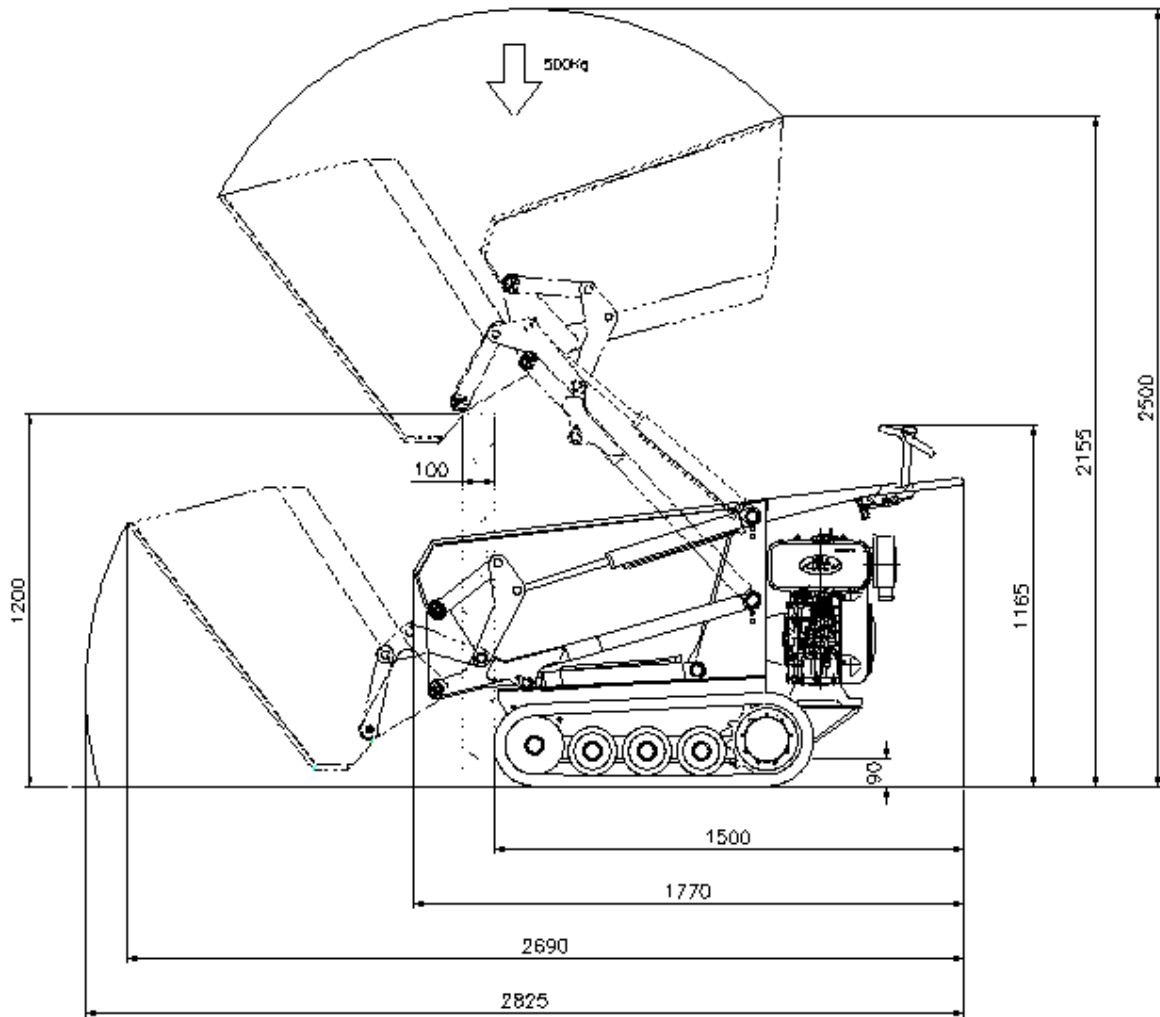

“Basic Overall Dimensions”

(Fig. 7)

General Specification

Hi- T 500		Diesel
Maximum Carrying Capacity	Kg (lbs)	500 (1100)
Skip Volume	Lt (ft ³)	255 (9.0)
Unladen Weight	Kg (lbs)	448 (987)
Width	mm (ins)	700 (28 ins)
Height	mm (ins)	1165 (45.8 ins)
Height Over Skip	mm (ins)	2500 (98.4 ins)
Height Under Skip	mm (ins)	1200 (47 ins)
Length	mm (ins)	1770 (69.6 ins)
Max Gradeability	%	45%
Turning Circle	mm (ins)	2000 (78.5)
Track Ground Pressure	Kg/cm ² (psi)	0.351 (4.99)
Engine (All with Electric Start)	kW (HP)	Kubota OC95 7.1 (9.5)
Speed Forward	Kph (Mph)	4 (2.5)
Speed Reverse	Kph (Mph)	2 (1.2)
Power Take Off	20 lt/m @ 120 bar	Optional
Noise Level	Lwa	99

General Specification (Fig. 8)

Miscellaneous Bolt & Nut Torque Specification

Friction coefficient total 0.14 for screws and nuts without after treatment as well as for phosphate nuts.

Tighten by hand.

If nothing special is indicated select correct torque limits from the following tabulations:

Metric ISO Thread DIN 13								
Size	6.9 Some Engine Bolts		8.8 Standard Hex Bolt		10.9 Some Engine Bolt		12.9 Standard Cap head	
	Nm	(lbfft)	Nm	(lbfft)	Nm	(lbfft)	Nm	(lbfft)
M6	8.5	(6.3)	10	(7.4)	14	(10.3)	17	(12.5)
M8	21	(15.5)	25	(18.4)	35	(25.8)	41	(30.2)
M10	41	(30.2)	49	(36.1)	69	(50.9)	83	(61.2)
M12	72	(53.1)	86	(63.4)	120	(88.5)	145	(106.9)
M14	115	(85)	135	(100)	190	(140)	230	(170)
M16	180	(133)	210	(155)	295	(218)	355	(262)
M18	245	(181)	290	(214)	400	(295)	485	(358)
M20	345	(255)	410	(302)	580	(428)	690	(509)
M22	465	(343)	550	(406)	780	(575)	930	(686)
M24	600	(443)	710	(524)	1000	(738)	1200	(885)
M27	890	(656)	1050	(774)	1500	(1106)	1800	(1328)
M30	1200	(885)	1450	(1070)	2000	(1475)	2400	(1770)

Torque Settings (Fig. 9)

Every 10 hours of operation (Daily Walk Around Inspection)

- Visually check engine for damage, listen for any unusual noises:

- Engine Air Cleaner, Inspect and remove any obstructions from the air cleaner inlet with the engine stopped:
- Check Engine oil level, add oil if low see lubrication chart, With the engine off, the oil should be just over the last thread at filler: (Note do not over fill).

Fabrications:

- Lubrication (greasing) Periodic lubrications of moving parts reduce to a minimum the possibility of mechanical failures:
- Check for any loose bolts or fixings, tighten as per bolt chart:
- Check for any oil leak's securely tighten any loose joints, replenish any loses:

Note:

- **Service air cleaners more often when operating under extremely dusty conditions.**
- **Do not wash the air cleaner element out with detergent replace with new.**

After first 50 hours of operating new or rebuilt components:

- With the engine off and body inverted, remove red top of filter, pull out filter.
- Check level refill hydraulic tank as per lubrication chart. Check oil level by remove dipstick if low fill through the filter housing until the level is 6mm below the tube in the base of the filter housing:
- Replace the hydraulic oil filter install new element each time do not reuse.
- Engine crankcase, drain oil replace as per lubrication chart check oil level the oil should be just over the last thread at filler: (Note do not over fill)
- Lubrication (greasing) Periodic lubrications of moving parts reduce to a minimum the possibility of mechanical failures:

Every 100 hours or operation (Monthly)

- Engine crankcase drain oil replace as per lubrication chart check oil level the oil should be just over the last thread at filler: (Note do not over fill)
- Lubrication (greasing): -periodic lubrications of moving parts reduce to a minimum the possibility of mechanical failures:
- General inspection check entire unit for leaks loose bolts and nuts or damaged parts. Examine the body, particularly the chassis, for cracks or broken welds. Repair where necessary.
- Engine air intake. Check air intake system for wear or damage to piping, loose clamps and leaks.

- Drain fuel remove filter screen replace the assemble install new filter screen and refill tank. If contaminated fuel is suspected frequency may need to be increased.

Every 300 hours of operation:

- Drain fuel and replace fuel filter.
- Lubrication (greasing): -Periodic lubrications of moving parts reduces to a minimum the possibility of mechanical failures.

Every 1000 hours of operation (6 Months):

- Lubrication (greasing): -Periodic lubrications of moving parts reduces to a minimum the possibility of mechanical failures.
- Replace hydraulic oil filter install new element each time do not reuse.

Every 2,000 hours of operation (Annually):

- Lubrication (greasing):- Periodic lubrications of moving parts reduces to a minimum, the possibility of mechanical failures.
- Hydraulic Oil Tank:-Drain oil, remove and clean filter screen assemblies. Reinstall filter screens and refill tank.
- Hydraulic Oil Filter Clean filter housing and install new element after a year or 2,000 hours of operation whichever comes first.

All information contained in the 'Lubrication and Service Chart' is extracted from the relevant manufactures Operators Manual and was correct at time of publication. User should ensure that information contained in this chart, regarding engines and hydraulics, reflect the information shown in the relevant manufacturers Operators Manuals, supplied with the machine. Maintenance procedures should be carried out in conjunction with any additional procedures contained in the relevant manufacturers 'Operation and Maintenance Manual', at the intervals specified.

Lubrication and Miscellaneous Servicing:

Small circles on the illustration represent points at which lubrication or servicing must take place, at the intervals indicated on the left-hand side of the lubrication chart.

Note:

1. The use of low viscosity oils, such as 10W or 10W - 30, can be used to aid in starting the engine and providing sufficient oil flow at ambient temperatures below -5°C (23°F). Continuous use of low viscosity oils can decrease engine life due to wear.
2. Operation below the minimum temperatures listed for the oil used without proper preheats or warm-up results in greatly reduced life. Proper warm-up requires 20 minutes minimum (with engine at part throttle) before operating.
3. Hydraulic Oil meeting specification is the only oil suitable for use in this hydraulic system.

6. Maintenance and Replacement Parts

Full access to the engine can be achieved by opening the right and left hand engine enclosures; this can be achieved as follows:

1. Remove air cleaner cover and filter.
2. Release and remove the three M8 bolts securing the air cleaner body and intake extension to the engine.
3. Release the enclosure clips.
4. Right hand enclosure will now swing outwards.
5. Should the need arise both enclosures can be removed.
6. Release and remove the 8no M6 Countersunk Head screws that attach the enclosures hinges to the chassis.

Do not release the screws that attach the hinges to the enclosures.

7. Re-assemble in the reverse order of the above, replacing gaskets and filter as necessary.

**DO NOT RUN ENGINE WITH THE AIR
CLEANER REMOVED.**

**ALWAYS REFIT THE AIR CLEANER SHOULD IT
BE NECESSARY TO RUN THE ENGINE.**

Replacement of Rubber Drive Track

In the event that the drive Track being displaced during operation follow the procedure listed below.



Typical view of displaced track

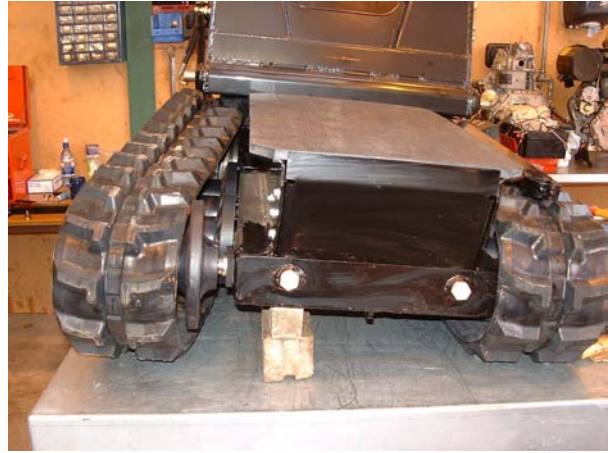

Support lower chassis along its length

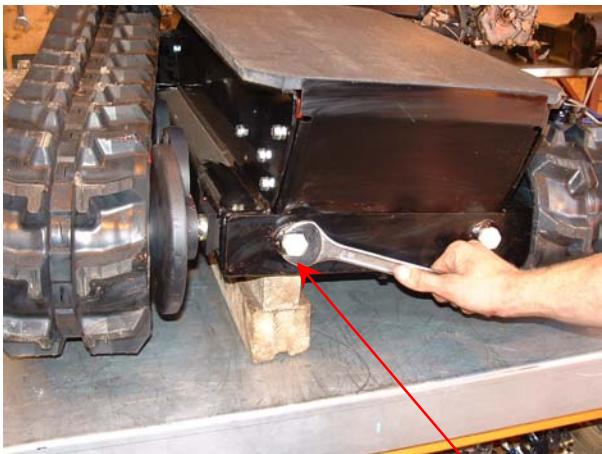

Remove blanking plugs

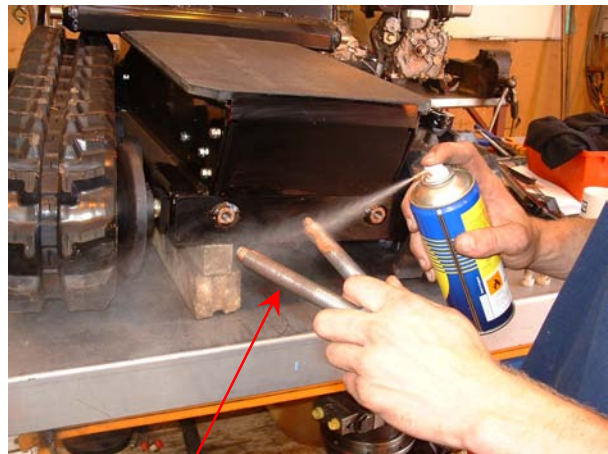

lubricate jacking bolts (supplied)



Insert jacking bolts adjust equally

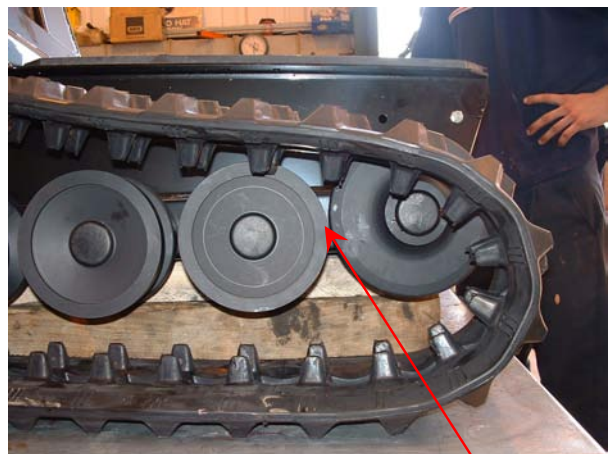

Adjust until idler is in line with roller



Remove blanking plug



Remove securing bolt



Remove Idler

Place Idler in drive track

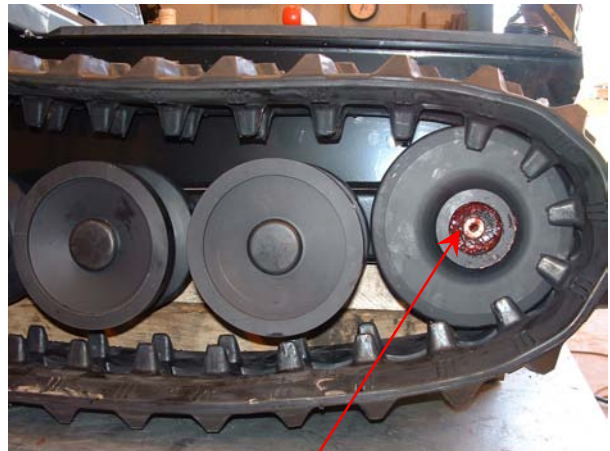
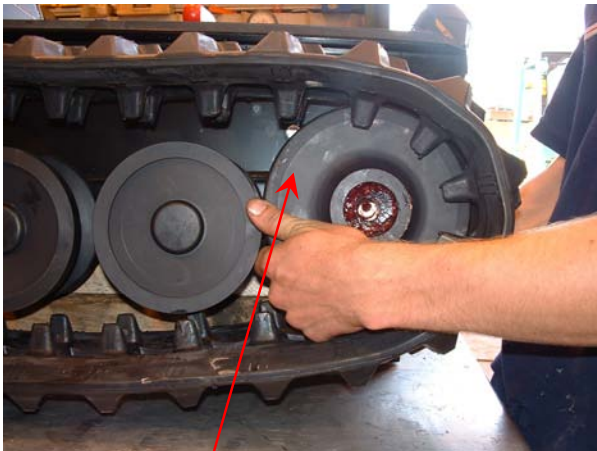

Slide drive track and Idler on shaft

Insure Idler is fully home



Install securing bolt (torque 49Nm)



Replace blanking plug

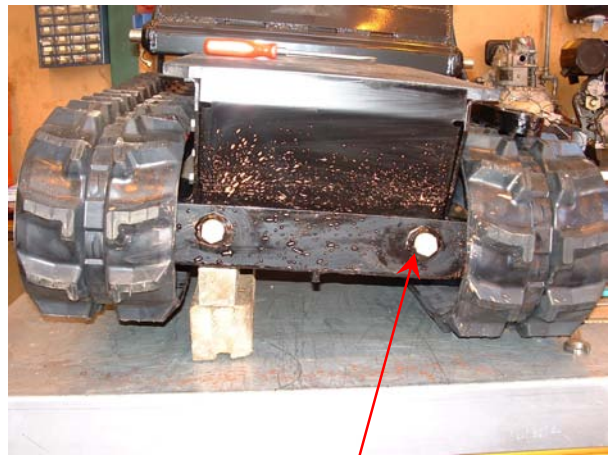

Remove jacking bolts

Replace blanking plugs



Remove any blocking under chassis run and test.

Assemblies and Parts Listings:

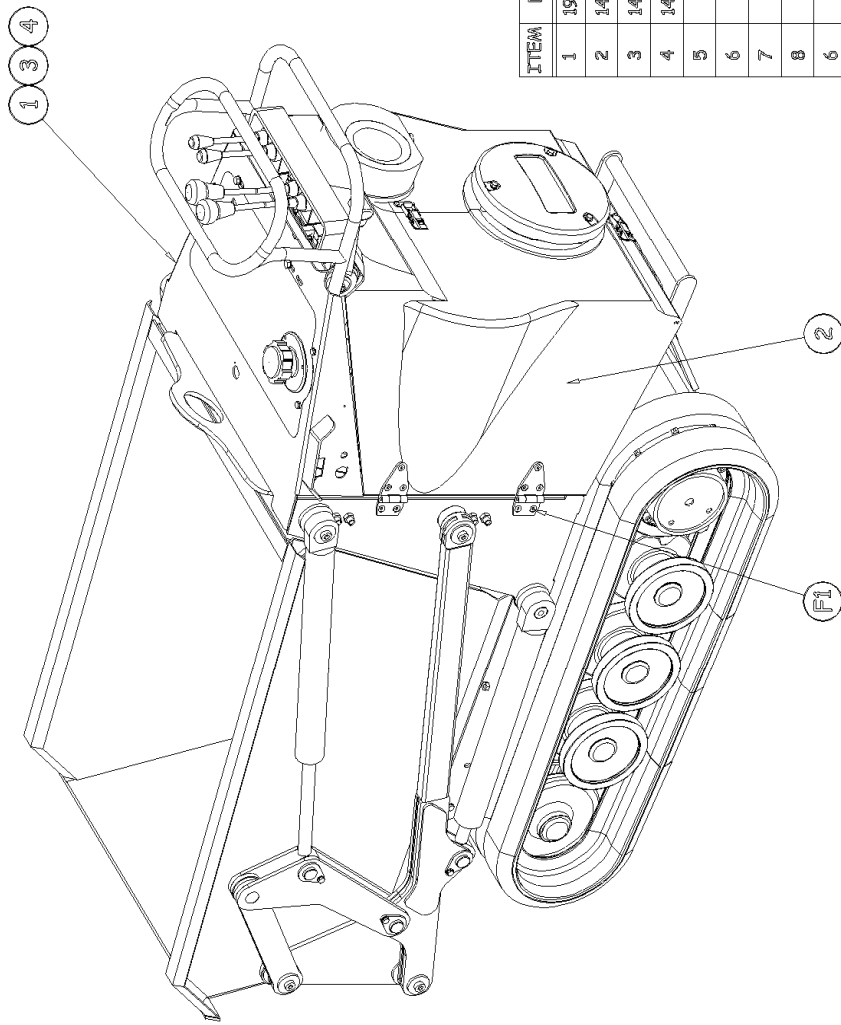

ITEM	DRG No.	PART No.	DESCRIPTION	QTY
1	1941-05 SA	SA-1601-05	CHASSIS ASSY - STAGE 5	1
2	1471 SA	SA-1471	ENGINE ENCLOSURE ASSY	1
3	1459 SA	SA-1459	HYDRAULIC ASSY	1
4	1467 SA	SA-1467	DECAL ASSY	1
5		03-0137	TAMPER PROOF SEAL	3
6		70-0150	HEAT SHRINK	0.02
7		80-0113	CABLE TIE	6
8		82-0001	JACKING BOLT M16	6
6		03-0002	TRACK PLUG - M16 PLASTIC	2
F1		01-0090	M6 x 16 SKT CSK HEAD SCREW	8

TAYLOR CONSTRUCTION PLANT LTD.
QUAYSIDE PARK, BATES ROAD,
MILTON, ESSEX, CB9 9PT
TEL: 44 (0)1473 84330
WWW.TCP.CO.UK

TITLE: TRACKED CARRIER ASSY
FIT500 MK4 V3 - 2006
DWG No. TCP-1940 6A
SHEET

ISS. A
DATE 22.11.2006

ITEM#	DRG No.	PART No.	DESCRIPTION	QTY
1	1462	50-0011	CHASSIS ASSY MK4	1
2	1005	51-0005	LIFTING EYE	1
3	1425	51-0004	GRAB BAR, CONTROL GUARD	1
4	003	51-0017	FRONT BUMPER	1
5		60-0019	TRACK MOTOR	2
6	053	20-0004	SPROCKET	2
7		02-0010	CLIP/DIP DOW 471	2
8	035	51-0012	SLIDE, FRONT AXLE	2
9	036	51-0022	FRONT AXLE	1
10	007	51-0013	SPRINGS GUIDE, AXLE	2
11		40-0001	SPRINGS OUTER	2
12		40-0003	SPRINGS INNER	2
13	062	51-0011	IDLER FRONT	2
14		03-0001	END CAP	8
15		20-0003	SEAL, DOUBLE LIP	8
16	051	51-0015	BOTTOM ROLLER	6
17		22-0001	TRACK RUBBER	2
18	1465	80-0076	DECAL CONTROL PANEL	1
19	1469 SA - ITEM 39		3/8-3/8 BSP MALE-MALE	6
20	1469 SA - ITEM 40		3/8 BONDED SEAL	6
F1		01-0011	M10 x 25 SKT HD SCREW - BLACK	10
F2		01-0010	M10 x 25 HEX SET BOLT	2
F3		02-0002	M10 WASHER	2
F4		01-0097	M10 x 25 SKT HD SCREW - BZP	18
F5		01-0010	M10 x 25 HEX SET SCREW	8
F6		02-0008	M10 SPRING WASHER	8
F7		02-0007	M10 WASHER, LARGE - SPECIAL	8
F8		01-0012	M8 x 30 HEX SET SCREW	2
F9		01-0020	M8 NUT	2
F10		01-0005	M8 x 20 HEX SET SCREWS	10
F11		02-0011	M8 WASHER	20
F12		01-0007	M8 NYLOC NUT	10
F13		01-0015	M12 x 25 SKT HD, LO PROFILE	5
F14		03-0002	TRACK FLUG - M16	2

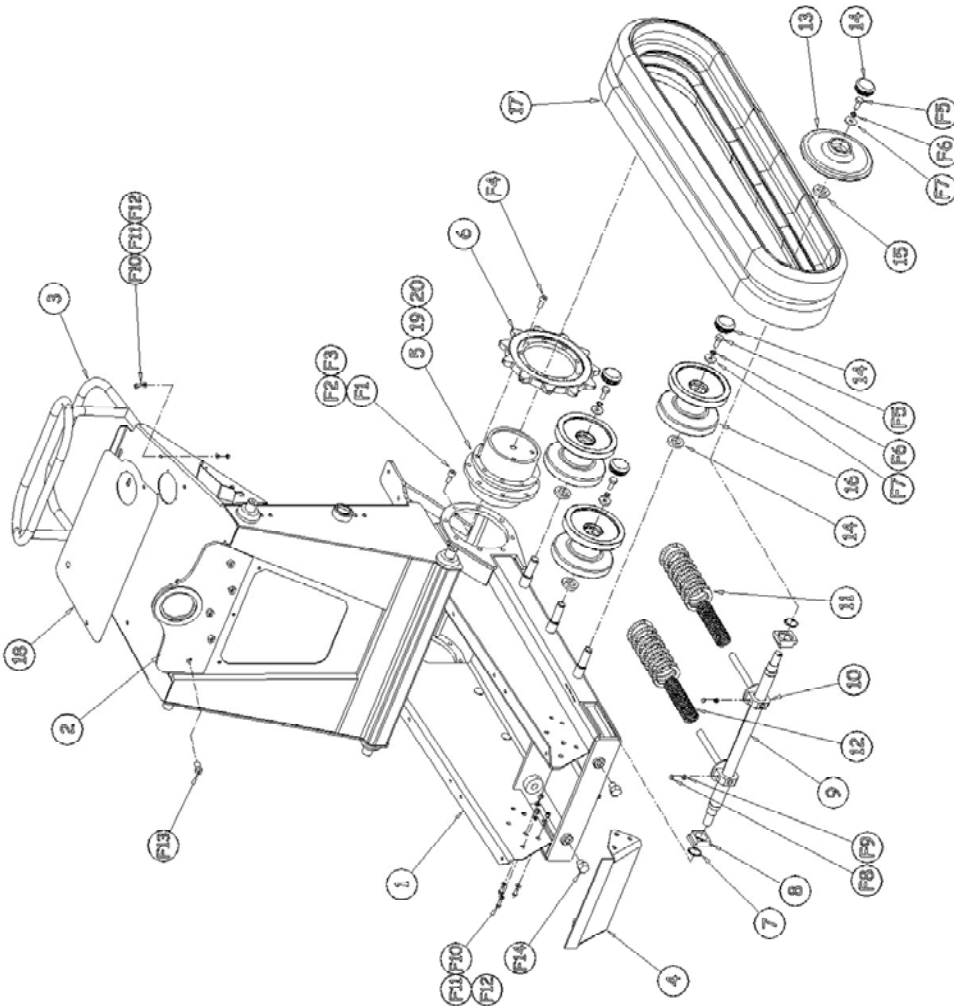

TAYLOR CONSTRUCTION PLANT LTD.
 CHANDLER ROAD, BATES ROAD,
 AULON, LESHAM, COV. CV14 4JG
 TEL: 01453 800777 FAX: 01453 813300
 WWW.TCP.CO.UK

TITLE: CHASSIS ASSY, STAGE 1
 MK4 V3 - 2006

DWG No. TCP-1941-01 SA
 STN. SA-1941-01
 DATE 23.11.06

ISS. A

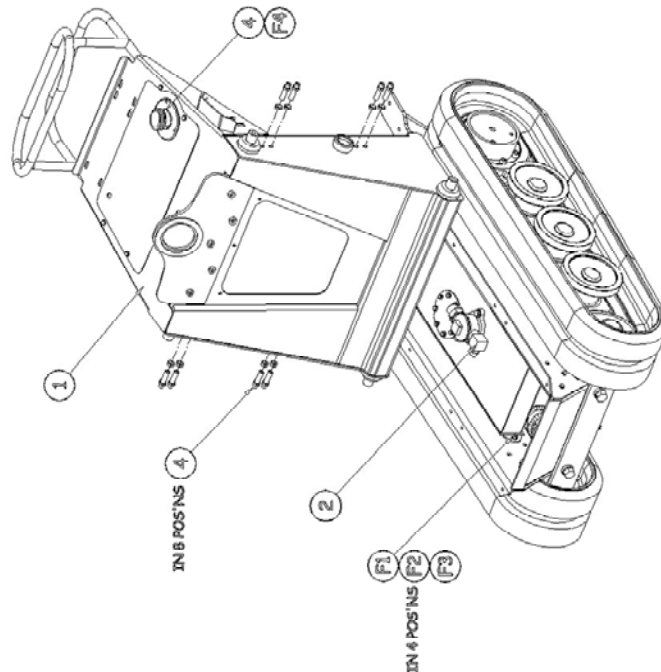
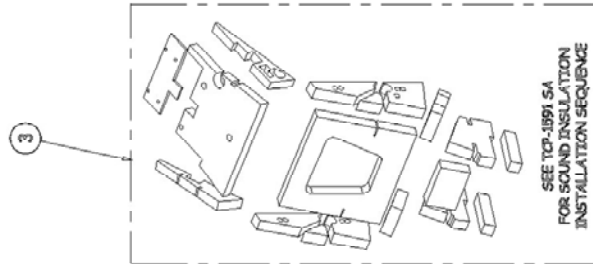

ITEM	DWG No.	PART No.	DESCRIPTION	QTY
1	1941-01 SA	SA-1941-01	CHASSIS ASSY MK4 - STAGE 1	1
2	1388 SA	69-0007	HYDRAULIC TANK ASSY	1
3	1591 SA	30-0005	SOUND INSULATION CHASSIS	1
4	1419	14-0010	FUEL FILLER - T-READED	1
5	1469 SA - ITEM 34		1/4 EXT'D BULLHEAD C/W NUT	8
6	1469 SA - ITEM 45		1/2 - 5/8 BSP MALE-MALE	2
7	1469 SA - ITEM 46		1/2 BONDED SEAL	2
8	1469 SA - ITEM 1		3/4 IN 320 CUT LENGTH 90° 90° @ 60°	1
9	1469 SA - ITEM 2		1/4 320 CUT LENGTH 90° 90° @ 90°	1
10	1469 SA - ITEM 7		3/8 2W 1460 CUT LENGTH 90° 90° @ 270°	1
11	1469 SA - ITEM 9		3/8 2W 1390 CUT LENGTH 90° 90° @ 270°	1
12	1469 SA - ITEM 3		1/4 320 CUT LENGTH 90° 90° @ 270°	1
13	1469 SA - ITEM 6		3/8 2W 1460 CUT LENGTH 90° 90° @ 135°	1
14	1469 SA - ITEM 10		3/8 2W 1390 CUT LENGTH 90° 90° @ 135°	1
15	1469 SA - ITEM 31		1/2-5/8 BARREL	1
16	1469 SA - ITEM 20		1/2 IN 590 CUT LENGTH 90° MALE	1
F1		01-0013	M6 x 25 HEX SET SCREW	4
F2		02-0011	M6 WASHER	8
F3		01-0007	M6 NYLOC NUT	4
F4		01-0087	M6 x 12 SKT HD SCREW /ST/ST	3

RH MOTOR
LH MOTOR

NOTE:
ITEMS 6 TO 15
NOT SHOWN

TAYLOR CONSTRUCTION PLANT LTD.
QUAYSIDE PARK, BATES ROAD,
HULL, NORTH YORKSHIRE, HU13 9SD
TEL: 44 (0)1482 727271 FAX: 44 (0)1482 727272
WWW.TCP.CO.UK

TITLE: CHASSIS ASSY, STAGE 2
PCT1600 MK4 V3 - 2006

DWG No. TCP-1941-02 SA **STN.** SA-1941-02

ISS. A
DATE 23.11.2006

ITEM	DWG No.	PART No.	DESCRIPTION	QTY
1	1941-02 SA	SA-1941-02	CHASSIS ASSY MK4 - STAGE 2	1
2	1006	51-0024	VALVE PROTECTOR	1
3	1598SA	60-0045	CONTROL VALVE ASSY - 2 SPEED	1
4	1470 SA	SA-1470	OIL COOLER ASSY	1
5	40-0002		THROTTLE LEVER & CABLE	1
6	SUPPLIED WITH ENGINE		IGNITION SWITCH	1
7	70-0007		IGNITION WARNING LIGHT	1
8	71-0002		HOUR COUNTER	1
9	1574-02A	73-0011	LOOM, TWO SPEED WITH RELAY	1
10		71-0007	RELAY ONLY - 2 POLE C/O 12V	A/R
11	1385	70-0041	RELAY GLIP	1
12	1574-02B	73-0012	LOOM, PIEZO SWITCH	1
13	1574-03A	73-0013	LOOM, ALPOLARIES WITH RELAY	1
14		71-0006	RELAY ONLY - 1 POLE 12V	A/R
15	1574-03B	73-0014	LOOM, PROXIMITY SWITCH	1
16		70-0020	PROXIMITY SWITCH	1
17	1574-03C	73-0015	LOOM, BUZZER	1
18	1574-04	73-0016	LOOM, COLD START	1
19	1925 SA	54-1925	COLD START ASSY	1
20	1459 SA	64-0009	HYDRAULIC ASSY LIST	1
F1		01-0013	M8 x 25 HEX SET SCREW	4
F2		02-0011	M8 WASHER	4
F3		01-0002	M6 x 20 HEX SET SCREW	5
F4		02-0004	M6 WASHER	7
F5		02-0003	M6 SPRING WASHER	5
F6		01-0004	M6 x 12 HEX SET SCREW	2
F7		01-0087	M5 x 12 SKT HEAD SCREW	2
F8		01-0031	M3 x 12 POZI PAN HEAD SCREW	2
F9		02-0017	M3 WASHER	2
F10		01-0032	M3 NYLOC NUT	2
F11		02-0015	3mm x 10 AL POP BUSH	4
F12		01-0085	M5 NYLOC NUT	1

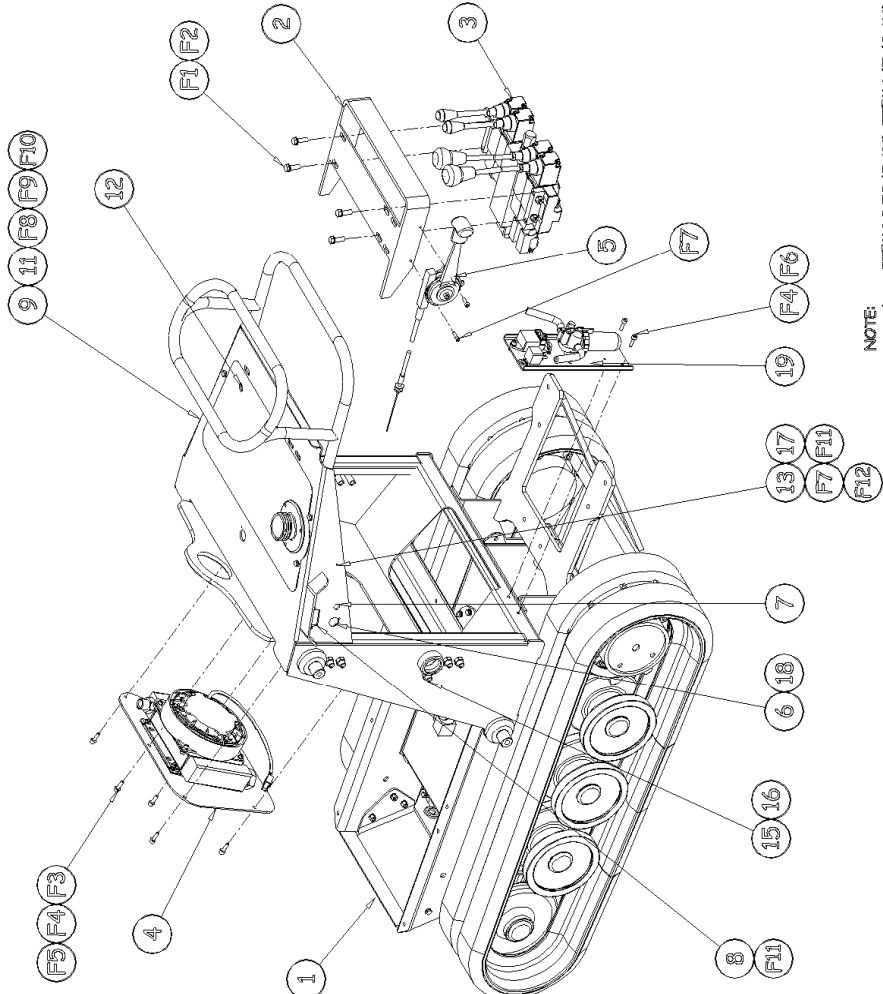

NOTE:
1. ITEMS 9 TO 15 AND ITEMS 17, 18 AND 20 NOT SHOWN FOR CLARITY.
2. ALL ELECTRICAL TERMINALS AND CONNECTORS TO BE TREATED WITH DIELECTRIC GREASE.

TAYLOR CONSTRUCTION PLANT LTD.
 CHASSIS ASSY MK4 - STAGE 3
 MCT500 MK4 v3 - 2006
 DWG No. TCP-1941-03 SA
 TITLE: CHASSIS ASSY, STAGE 3
 MCT500 MK4 v3 - 2006
 STR. No. SA-1941-03
 Iss. A
 DATE 23.12.2006

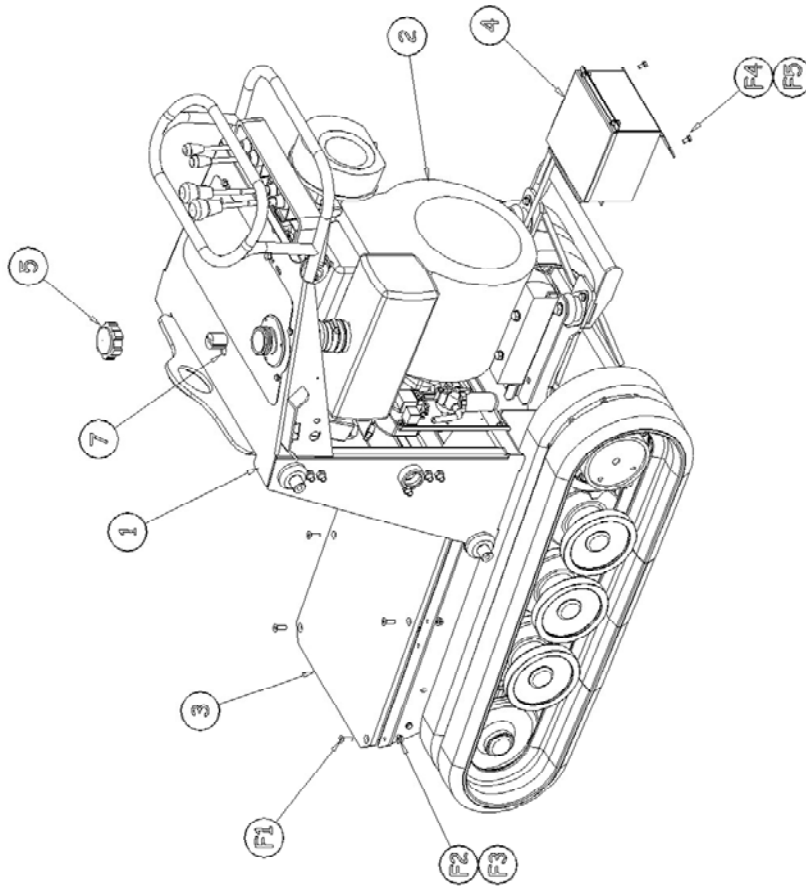

ITER#	DRG No.	PART No.	DESCRIPTION	QTY
1	1941-03 SA	SA-1941-03	CHASSIS ASSY MK4 -STAGE 3	1
2	1928-01 SA	SA-1928-01	ENGINE ASSY & DRESSING KIT	1
3	1008	SI-0014	COVER PLATE, CHASSIS	1
4	1468 SA	SA-1468	BATTERY BOX ASSY	1
5	1101	14-0014	FUEL CAP, VENTED	1
6		80-0001	SERIAL NO. PLATE	1
7		03-0016	BLANKING GROMMET Ø23	1
F1		01-0014	M8 x 25 SKT CSK HEAD SCREW	6
F2		01-0007	M8 NLOC NUTS	6
F3		02-0011	M8 WASHER	6
F4		01-0004	M6 x 12 HEX HEAD SET SCREW	2
F5		02-0004	M6 WASHER	2
F6		02-0015	Ø3 x 10 AL POP RIVETS	4

TAYLOR CONSTRUCTION PLANT LTD.
 CHASSIS ASSY MK4 -STAGE 4
 M/T300 MK4 V3 - 2006
 CHASSIS ASSY MK4 -STAGE 4
 M/T300 MK4 V3 - 2006
 DWG No. TCP-1941-04 SA
 STR.# SA-1941-04
 ISS. A
 DATE 23.11.2005

NOTE:
GREASE PIVOT PINS, SHAFTS AND BUSHES
ON ASSEMBLY.

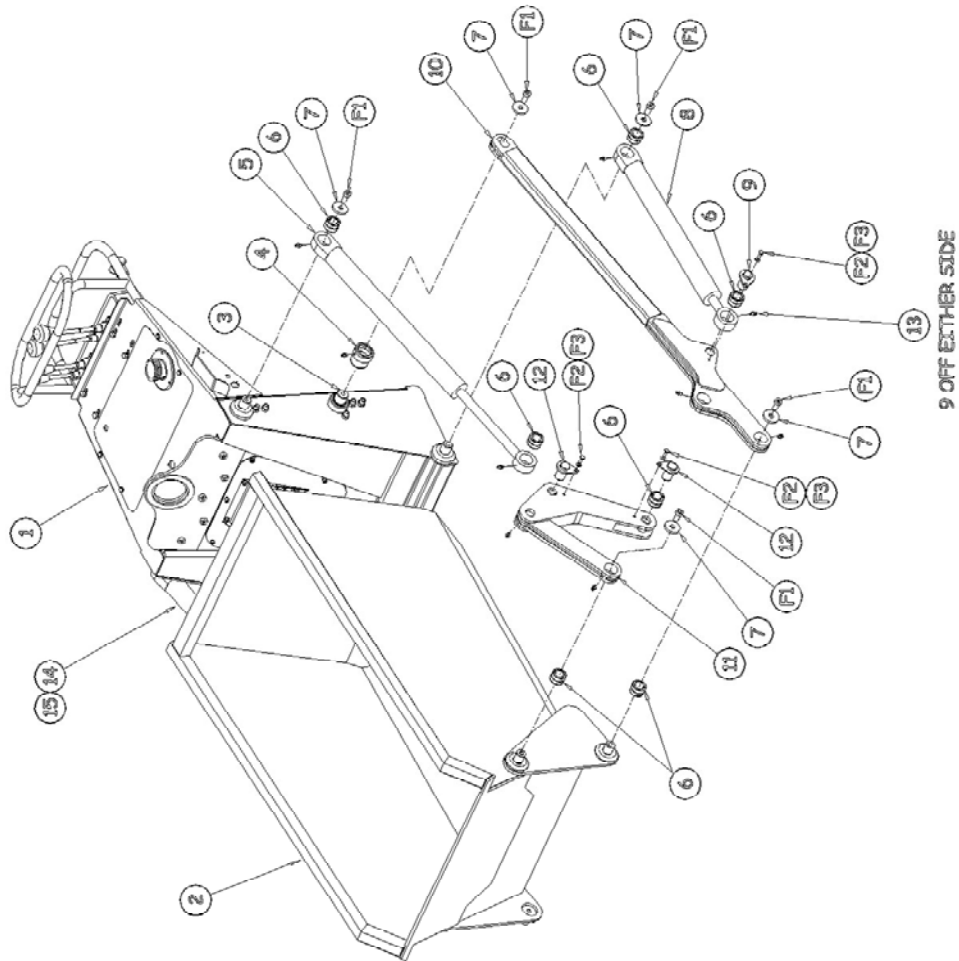

ITEM	DWG No.	PART No.	DESCRIPTION	QTY
1	1941-04 SA	SA-1941-04	CHASSIS ASSY MK4 - STAGE 4	1
2	014	B1-0001	BODY, STANDARD	1
3	045	B1-0003	CROSS SHAFT	1
4	049	20-0002	CROSS SHAFT BUSH	2
5	010-01	60-0015	TOP CYLINDER - LESS R/V	1
6	050	20-0001	PIVOT BUSH	14
7		02-0006	CLAMP WASHER	10
8	011-01	60-0016	LOWER CYLINDER - LESS R/V	1
9	028	50-0004	CYLINDER PIN - LOWER	2
10	029	B1-0018	LOWER ARM	2
11	1001	B1-0016	PIVOT LINK	2
12	069	50-0003	CYLINDER PIN - UPPER	4
13		02-0005	GREASE NEPHE	18
14	010-02	60-0028	TOP CYLINDER - WITH R/V	1
15	011-02	60-0029	LOWER CYLINDER - WITH R/V	1
16	1499 SA - ITEM 18		1/4 HOSES SLEEVED PAIR	2
17	1499 SA - ITEM 19		1/4 HOSES SLEEVED PAIR	2
F1		01-0003	M12 x 25 SKT HEAD SCREW	10
F2		01-0004	M6 x 16 HEX SET SCREW	6
F3		02-0004	M6 WASHER PLAT	6

TAYLOR CONSTRUCTION PLANT LTD.
 1000 WILSON ROAD, WILSON, ONT. L9L 1W1
 TEL: 416-218-8077 FAX: 416-218-4330
 WWW.TCP.EJ.COM

TITLE: CHASSIS ASSY, STAGE 5
 M17000 MK4 V3 - 2006

DWG No. TCP-1941-05 SA
 REV. SA-1941-05

ISS. A
 DATE 24.11.2005

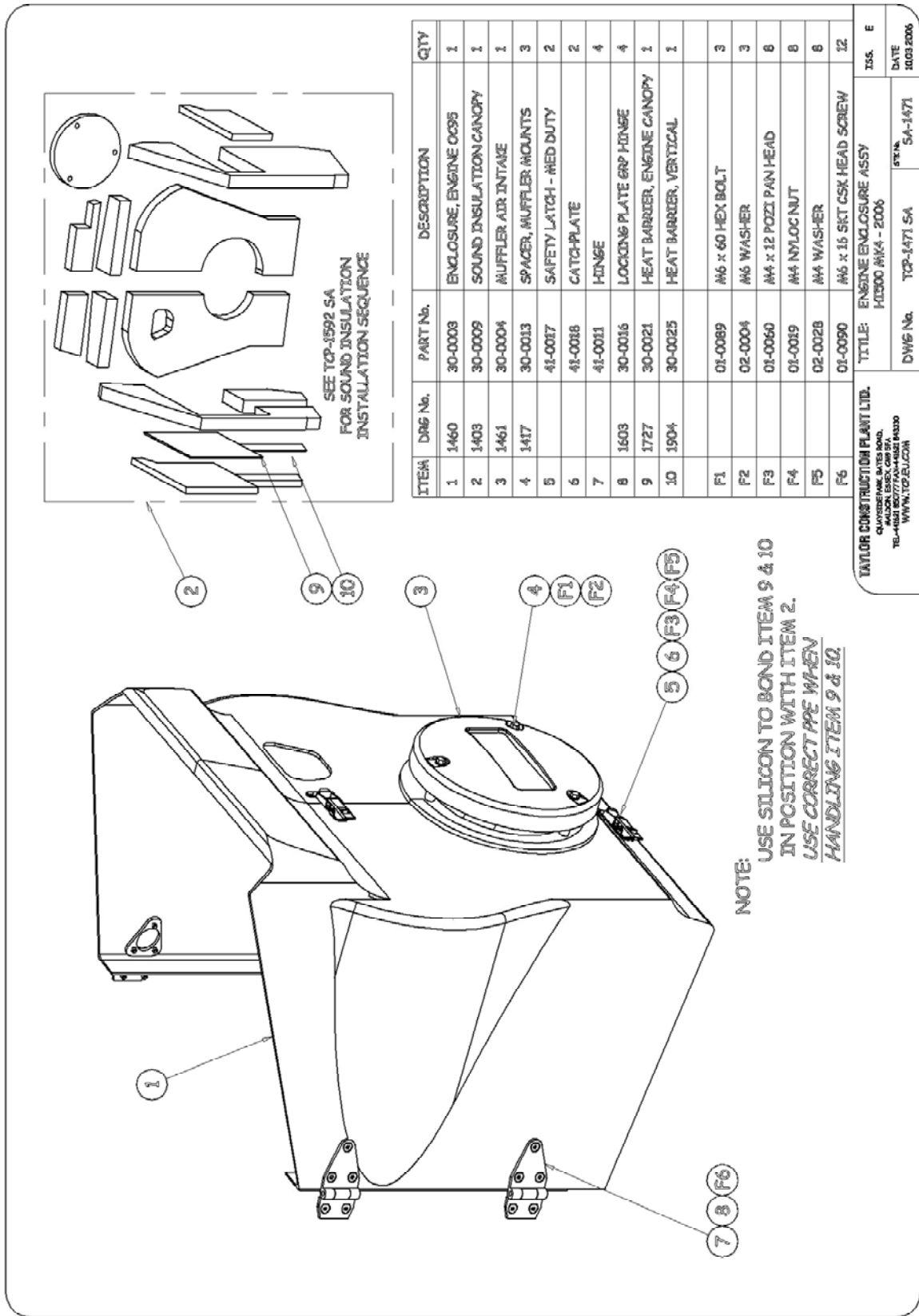

ITEM	DRG No.	PART No.	DESCRIPTION	QTY
1	1460	30-0003	ENCLOSURE, ENGINE 0095	1
2	1403	30-0009	SOUND INSULATION CANOPY	1
3	1461	30-0004	MUFFLER AIR INTAKE	1
4	1417	30-0013	SPACER, MUFFLER MOUNTS	3
5		41-0017	SAFETY LATCH - MED DUTY	2
6		41-0018	CATCH-PLATE	2
7		41-0011	HINGE	4
8	1603	30-0016	LOCKING PLATE GRP HINGE	4
9	1727	30-0021	HEAT BARRIER, ENGINE CANOPY	1
10	1904	30-0025	HEAT BARRIER, VERTICAL	1
F1		01-0089	M6 x 60 HEX BOLT	3
F2		02-0004	M6 WASHER	3
F3		01-0060	M4 x 12 POZI PAN HEAD	8
F4		01-0019	M4 NYLOC NUT	8
F5		02-0028	M4 WASHER	8
F6		01-0090	M6 x 16 SKT CSK HEAD SCREW	12

TAYLOR CONSTRUCTION PLANT LTD.
 CHAYBESIDE PARK, BATES ROAD,
 MALDON, ESSEX, SUFF. SA.
 TEL: 4481 80777 FAX: 4481 84330
 WWW.TCP.CO.UK

TITLE: ENGINE ENCLOSURE ASSY
 H1000 MKA - 2006

DWG No. TCP-1471 SA
 STN No. SA-1471

ISS. E
 DATE 10032006

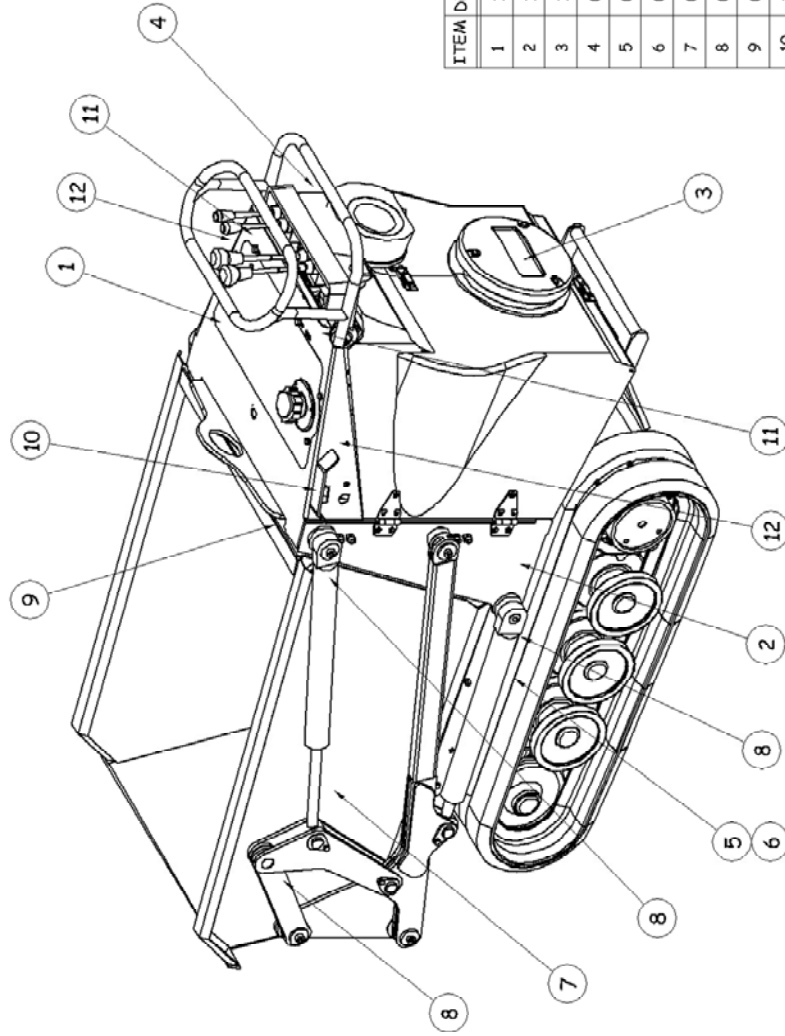

ITEM	DRG No.	PART No.	DESCRIPTION	QTY
1	1464	80-0076	DECAL, CONTROL PANEL	1
2	1101	80-0001	DATA PLATE, SERIAL No.	1
3	1465	80-0077	DECAL, MUFFLER	1
4	008	80-0004	DECAL WARNING HOT EXHAUST	2
5	011	80-0012	DECAL OIL FILTER & DIPSTICK	1
6	003	80-0005	DECAL OIL FILLER	1
7	001	80-0010	DECAL "HIT 500" BODY LOGO	2
8	006	80-0003	DECAL WARNING CRUSH ZONE	6
9	057	80-0013	DECAL CAUTION SIGN (L6E BODY)	1
10	1726	80-0236	DECAL STARTING INSTRUCTIONS	1
11	007	80-0009	DECAL WARNING KEEP CLEAR	2
12	002	80-0007	DECAL "CE" MARKING	2
13	012	80-0011	DECAL PTO (OPTIONAL)	1

TCP-1602-01
 CHRYSLER PAKES BATES NO. 1464
 TEL: +44(0)1507774444 FAX: +44(0)1507774444
 WWW.TCP.EU.COM

TITLE: DECAL ASSY LIST
 HIT500 MK4 - 2006

DWG No. TCP-1467 SA
 DRW. SA-1467
 ISS 8
 DATE 10.03.2006

ITEM	DWG No.	PART No.	DESCRIPTION	QTY
1	1414	51-0184	BATTERY BOX BASE	1
2	1415		BATTERY BOX LID	1
3	1418	30-0007	BOX LINER	1
4		70-0037	BATTERY	1
5	1059	73-0004	BATTERY LEADS	1
6		70-0066	CHARGER LEAD, BATTERY	1
F1		01-0087	M5 x 12 SKT HD SCREW	2
F2		02-0029	M5 WASHER	4
F3		01-0085	M5 NYLOC NUT	2

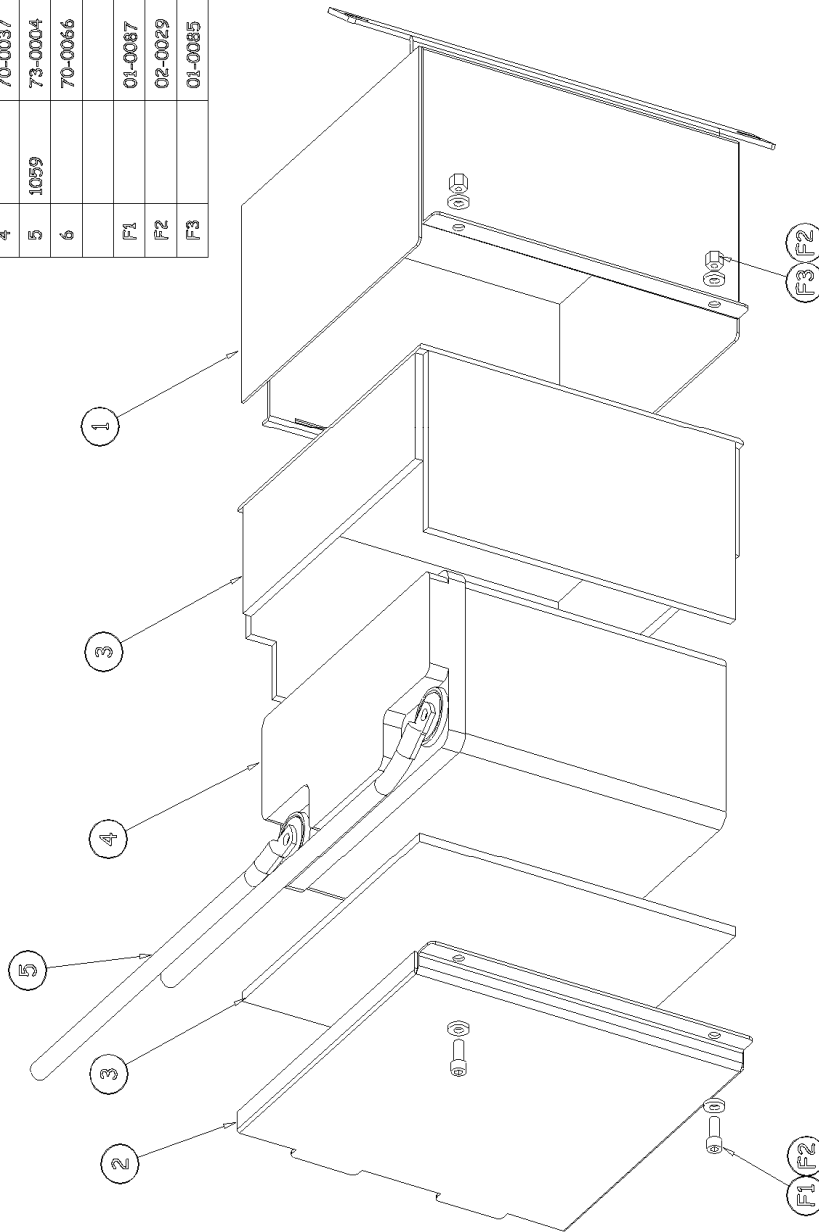

TAYLOR CONSTRUCTION PLANT LTD.
QUAYSIDE PARK, BATES ROAD,
MALDON, ESSEX, CB9 5PA
TEL: 01465 841399
WWW.TCP.EU.CO.UK

TITLE: BATTERY BOX ASSY
HITS00 MI4 2006

DWG No. TCP-1498 SA
STN. SA-1468

ISS. A
DATE 10.02.2006

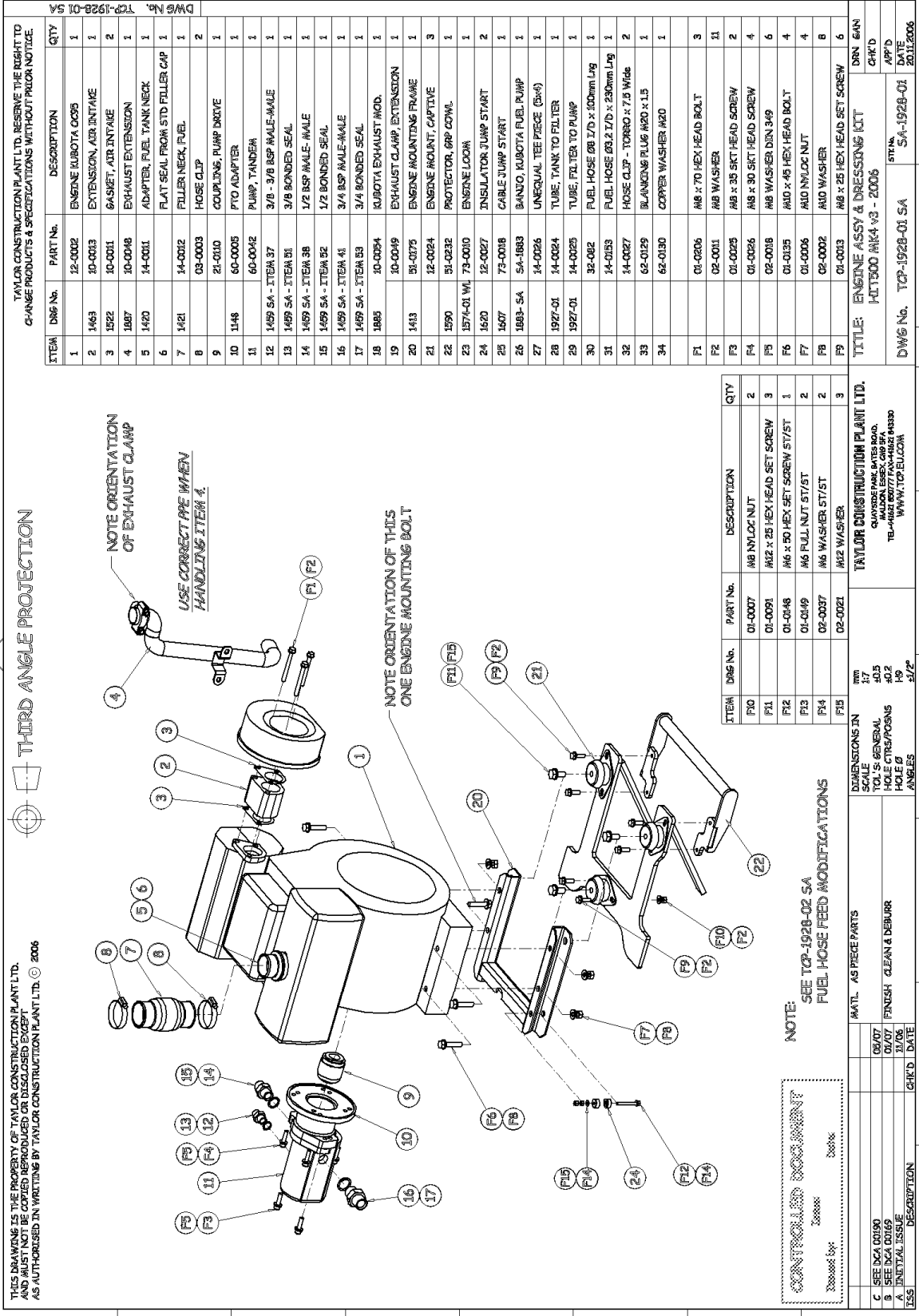

TAYLOR CONSTRUCTION PLANT LTD. RESERVE THE RIGHT TO CHANGE PRODUCTS & SPECIFICATIONS WITHOUT PRIOR NOTICE.

ITEM	DWG No.	PART No.	DESCRIPTION	QTY
1		12-0002	ENGINE KUBOTA 0095	1
2	1463	10-0003	EXTENSION, AIR INTAKE	1
3	1522	10-0001	GASKET, AIR INTAKE	2
4	1487	10-0048	EXHAUST EXTENSION	1
5	1420	14-0001	ADAPTER, FUEL TANK NECK	1
6			FLAT SEAL FROM STD FILLER CAP	1
7	1421	14-0002	FILLER NECK, FUEL	1
8			HOSE CLIP	2
9		21-0110	COUPLING, PUMP DRIVE	1
10	1148	60-0005	PTO ADAPTER	1
11		60-0042	PUMP, TANDEM	1
12	1459 SA - ITEM 37	3/8 - 3/8 BSP MALE-MALE		1
13	1459 SA - ITEM 38	1/2 BSP MALE-MALE		1
14	1459 SA - ITEM 38	1/2 BSP MALE-MALE		1
15	1459 SA - ITEM 38	1/2 BONDRO SEAL		1
16	1459 SA - ITEM 41	3/4 BSP MALE-MALE		1
17	1459 SA - ITEM 53	3/4 BONDRO SEAL		1
18	1889	10-0094	KUBOTA EXHAUST MOD.	1
19		10-0049	EXHAUST CLAMP EXTENSION	1
20	1413	51-0375	ENGINE MOUNTING FRAME	1
21		12-0024	ENGINE MOUNT, CAPTIVE	3
22	1590	51-0232	PROTECTOR, GRP CONVL	1
23	1574-01 V4	73-0010	ENGINE LOOM	1
24	1520	12-0027	INSULATOR JUMP START	2
25	1507	73-0018	CABLE JUMP START	1
26	1883 - SA	5A-1883	BANJO, KUBOTA FUEL PUMP	1
27		14-0026	UNEQUAL TEE PIECE (55x4)	1
28	1927-01	14-0024	TUBE, TANK TO FILTER	1
29	1927-01	14-0025	TUBE, FILTER TO PUMP	1
30		32-002	FUEL HOSE Ø8 3/8 x 100mm Lg	1
31		14-0153	FUEL HOSE Ø9.2 1/8 x 230mm Lg	1
32		14-0027	HOSE CLIP - TORISO x 7.5 Wide	2
33		62-0129	BALANCING PLUG M20 x 1.5	1
34		62-0130	COPPER WASHER M20	1
F1		01-0206	M8 x 70 HEX HEAD BOLT	3
F2		02-0011	M8 WASHER	11
F3		01-0025	M8 x 35 SCT HEAD SCREW	2
F4		01-0056	M8 x 30 SCT HEAD SCREW	4
F5		02-0018	M8 WASHER DIN 349	6
F6		01-0135	M10 x 45 HEX HEAD BOLT	4
F7		01-0006	M10 NYLOC NUT	4
F8		02-0002	M10 WASHER	8
F9		01-0013	M8 x 25 HEX HEAD SET SCREW	6

DWG No. TCP-1928-01 SA

TITLE: ENGINE ASSY & DRESSING KIT

SCALE: 1:1

DATE: 06/07

DATE: 06/07

DATE: 06/07

DATE: 06/07

THIS DRAWING IS THE PROPERTY OF TAYLOR CONSTRUCTION PLANT LTD. AND MUST NOT BE COPIED, REPRODUCED OR DISCLOSED EXCEPT AS AUTHORIZED IN WRITING BY TAYLOR CONSTRUCTION PLANT LTD. © 2006

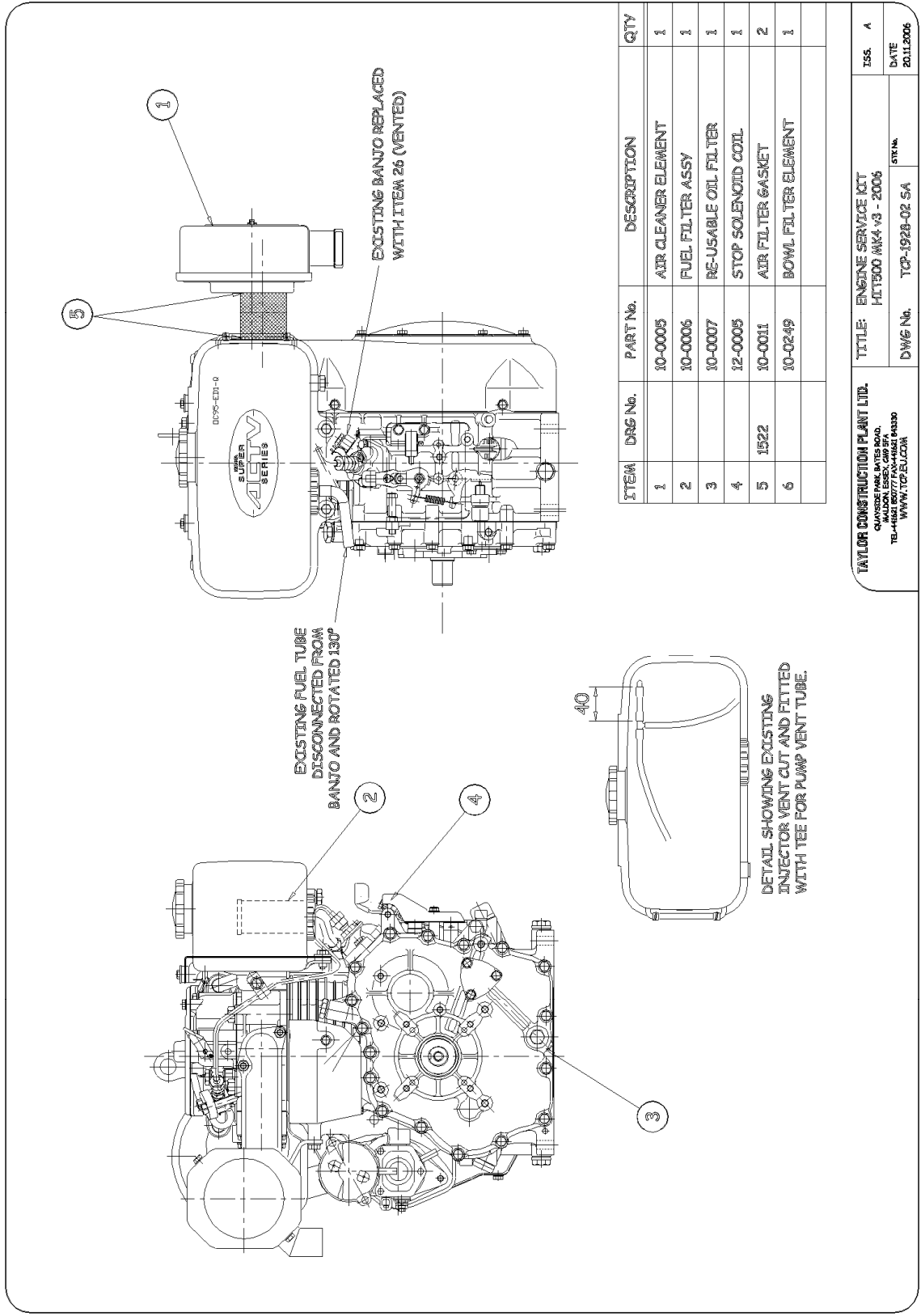

ITEM	DRG No.	PART No.	DESCRIPTION	QTY
1		10-0005	AIR CLEANER ELEMENT	1
2		10-0006	FUEL FILTER ASSY	1
3		10-0007	RE-USABLE OIL FILTER	1
4		12-0005	STOP SOLENOID COIL	1
5	1522	10-0011	AIR FILTER GASKET	2
6		10-0249	BOWL FILTER ELEMENT	1

TAYLOR CONSTRUCTION PLANT LTD.
 QUAYSIDE PARK BATES ROAD,
 WALTON, ESSEX, CUP 8PA
 TEL: 04641 86077 FAX: 04641 84300
 WWW.TCP.CO.UK

TITLE: ENGINE SERVICE KIT
 HET500 MK4 v3 - 2006

DWG No. TCP-1928-02 SA

ISS. A

DATE 2011.006

- ASSEMBLY NOTES:**
1. DISMANTLE FAN FROM OIL COOLER AND RE-ASSEMBLE IN THE PORTING CONFIGURATION SHOWN.
 2. REMOVE CONNECTOR BLADES FROM SHROUD AND RE-ASSEMBLE WITH THE WIRE COLOURS AS SHOWN (REVERSE FAN ROTATION).
 3. FIT DIODE IN LINE AS SHOWN. (NOTE ORIENTATION).

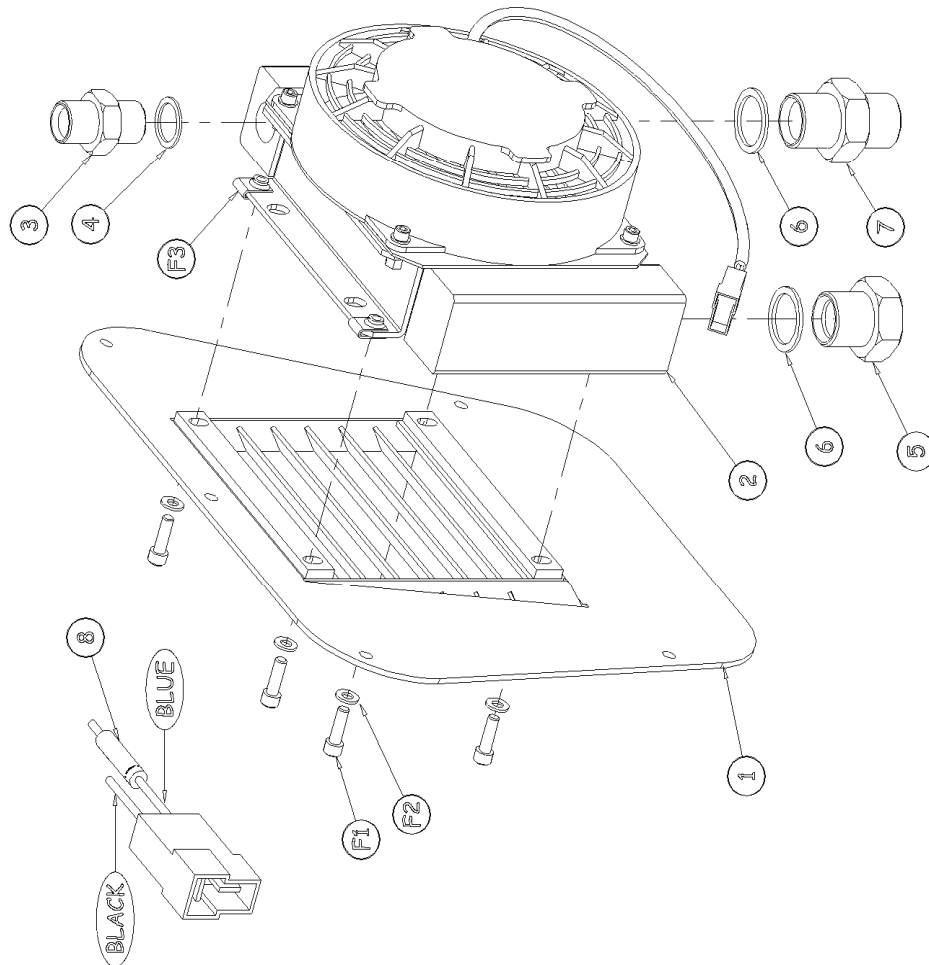

ITEM	DRG No.	PART No.	DESCRIPTION	QTY
1	1416	51-0185	OIL COOLER MOUNT PLATE	1
2		61-0007	OIL COOLER WITH 12V FAN	1
			SEE ASSY NOTES ABOVE	
3	1459 SA - ITEM	38	1/2 BSP MALE-MALE	1
4	1459 SA - ITEM	54	1/2 COPPER SEAL	1
5	1459 SA - ITEM	49	3/4 BLANKING PLUG	1
6	1459 SA - ITEM	53	3/4 BONDED SEAL	2
7	1459 SA - ITEM	45	3/4 - 5/8 MALE - MALE	1
8		70-0005	DIODE	1
F1		01-0045	M6 x 25 SKT HEAD SCREW	4
F2		02-0004	M6 WASHER	4
F3		03-0009	M6 LUG NUTS	4

TAYLOR CONSTRUCTION PLANT LTD.
 QUAYSIDE MARK BATES ROAD,
 MILLON, L650C, CHAS ST,
 TEL: 01457 511120
 WWW.TCP.EU.COM

TITLE: COOLER ASSY, HYDRAULIC
 HT1500 MK4 2006

DWG No. TCP-1470 SA
ISS. 4
DATE 28.02.2006

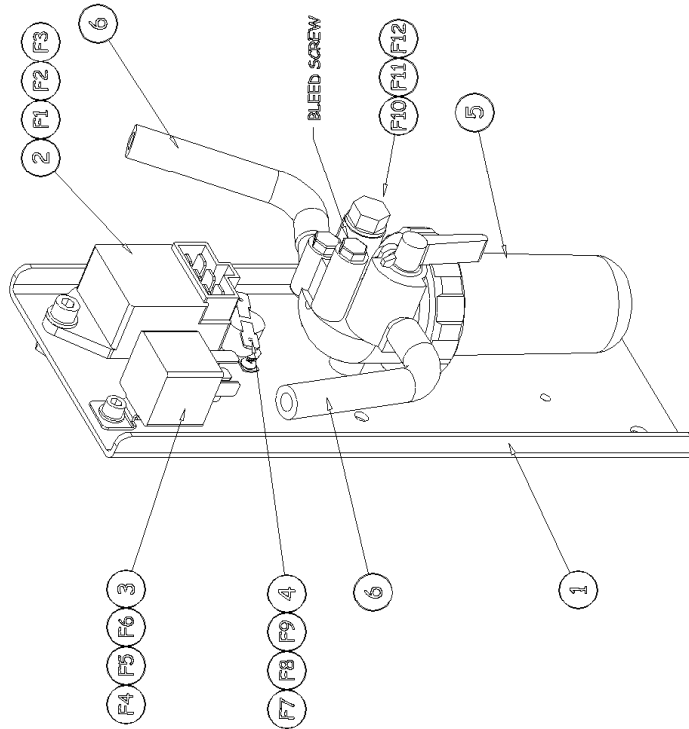

ITEM	DRG No.	PART No.	DESCRIPTION	QTY
1	1573	51-0279	COLD START BRACKET	1
2		70-0065	TIMER RELAY	1
3		71-0153	RELAY	1
4		70-0265	TEMPERATURE SWITCH	1
5		10-0250	FUEL FILTER ASSY (Complete)	1
6		14-0009	FUEL HOSE (Complete with clips)	2
F1		01-0079	M6 x 16 HEX HD SET SCREW	1
F2		01-0017	M5 NYLOC NUT	1
F3		02-0004	M6 WASHER	2
F4		01-0041	M5 x 12 HEX HD SET SCREW	1
F5		01-0085	M5 NYLOC NUT	1
F6		02-0013	M5 WASHER	2
F7		01-0031	M3 x 12 POZI HEAD SCREW	2
F8		02-0017	M3 WASHER	4
F9		01-0032	M3 NYLOC NUT	2
F10		01-0151	M6 X 65 HEX HD BOLT	1
F11		01-0007	M8 NYLOC NUT	1
F12		02-0011	M8 WASHER	2

TAYLOR CONSTRUCTION PLANT LTD.
QUAYSIDE PARK BATES ROAD,
MILTON, ESSEX, SSG1 2FA,
ENGLAND. TEL: 01277 771111 FAX: 01277 771122
WWW.TCP.CO.UK

TITLE: COLD START ASSY - 5 SEC DELAY +
KUBOTA FILTER FET300 MK4 v3
DWG No. TCP-1925 SA
ISS. A
DATE 16.12.06

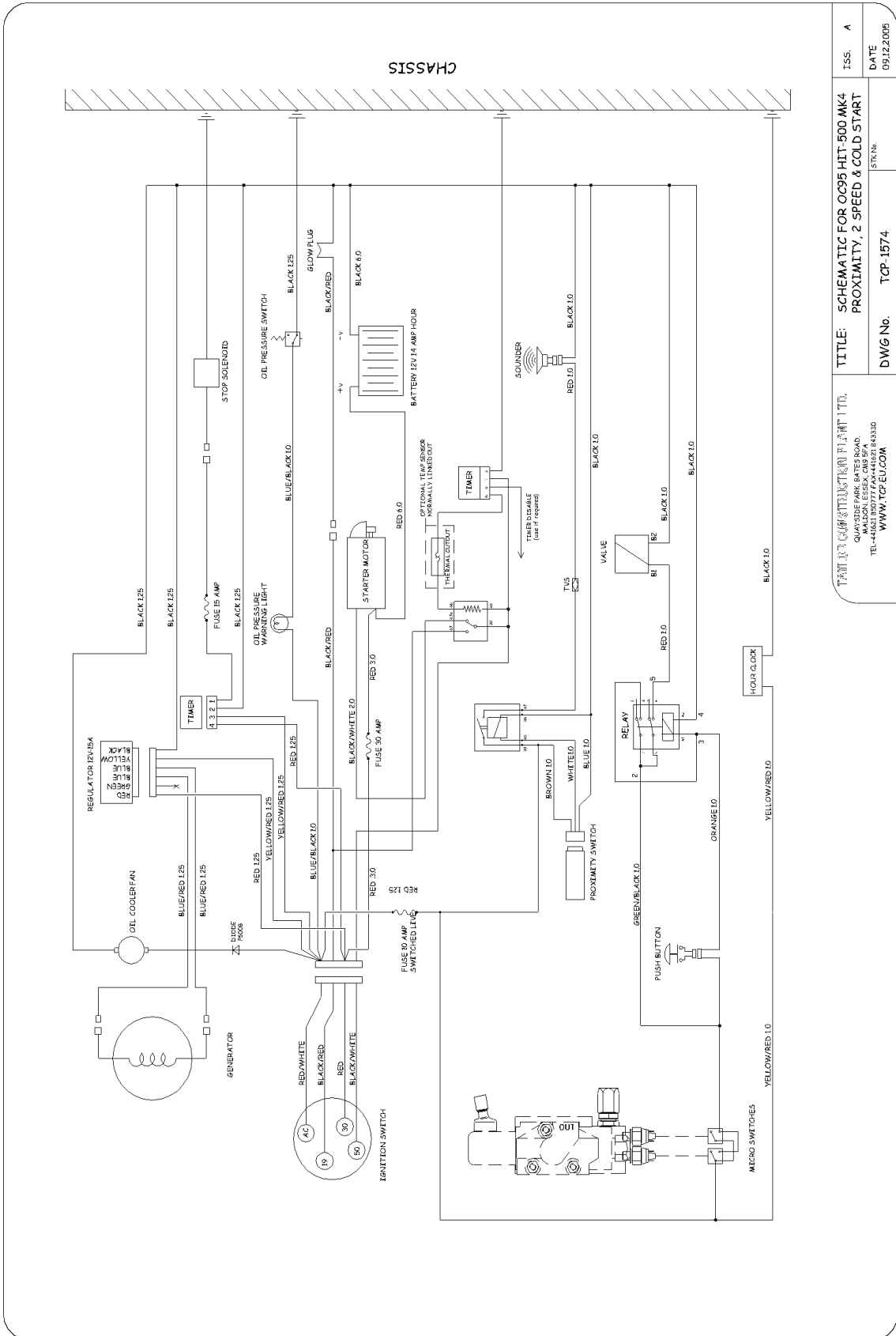

TITLE: SCHEMATIC FOR OC95 HIT-500 MK4 PROXIMITY, 2 SPEED & COLD START		ISS. A
DWG No. TCP-1574		DATE: 09.12.2005
STATION		
TAI TRADING CORPORATION PVT. LTD. QUAYSIDE PARK, BATES ROAD, WALTON, ESSEX, SMO 5PT, UK TEL: +44 (0)1473 843310 WWW.TCFEU.COM		

- N.B. 1. ALL CONNECTORS VIEWED FROM WIRING SIDE.
2. SEE CONNECTOR SPEC SHT.2 OF 2.
3. USE FLEXIBLE SHRINK WRAP.

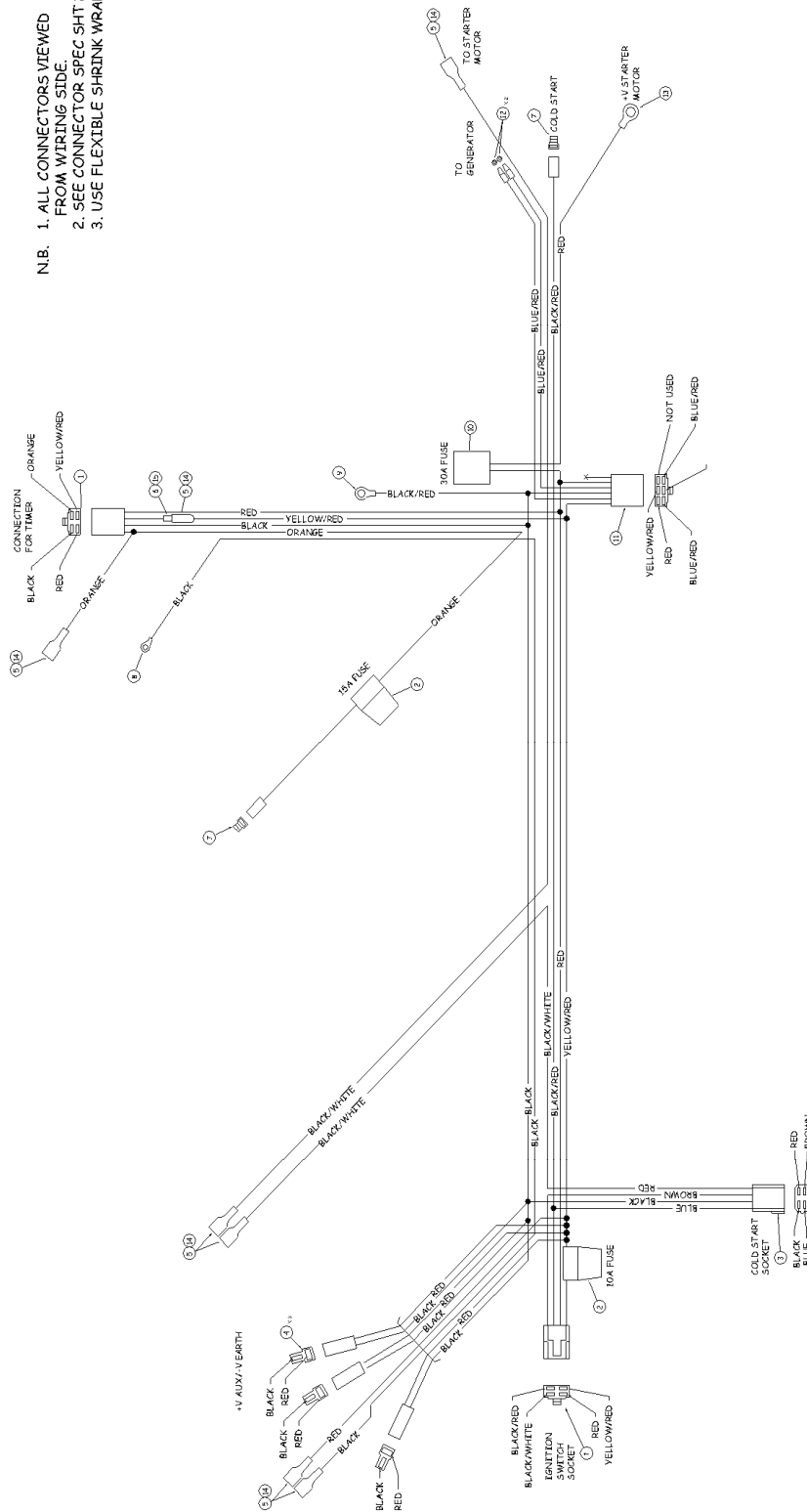

SHT. 1 OF 2

TITLE: WIRING LOOM FOR KUBOTA OC95 HIT 500 MK4 - 2006		ISS. A
DWG No. TCP-1574-01 WL		DATE 13.12.2005
STATION: 73-0010		

TAKI LTD. (UK) DISTRIBUTION PLANT LTD.
 QUAYSIDE PARK BRATES ROAD,
 TEL-44(0)1807777777 FAX-44(0)1807777777
 WWW.TCP-EU.COM

Operation - Safety – Maintenance
TCP-1602-01 Issue I

ITEM	STK. No.	DESCRIPTION	MANUFACTURER	PART No.	QTY
1		RECEPTACLE HOUSING 4 WAY (S)	SUPPLIED WITH ENGINE		2
2	70-0149	IN-LINE FUSE HOLDER	DURITE	0-376-90	2
3	70-0054	RECEPTACLE HOUSING 4 WAY	TYCO ELECTRONICS	180900-0	1
4	70-0050	RECEPTACLE HOUSING 2 WAY 'T'	TYCO ELECTRONICS	180907-0	3
5	70-0060	6.3 IN-LINE RECEPTACLE	RS	503LT	7
6	70-0062	6.3 BLADE	RS	DOM6.3-2.5 LT	1
7		RECEPTACLE HOUSING 1 WAY (S)	SUPPLIED WITH ENGINE		2
8		M5 RING CRIMP TERMINAL	DURITE	0-001-02	1
9		M6 RING CRIMP TERMINAL	SUPPLIED WITH ENGINE		1
10		FUSE HOLDER (S)	SUPPLIED WITH ENGINE		1
11		RECEPTACLE HOUSING 6 WAY (S)	SUPPLIED WITH ENGINE		1
12		Ø4 CRIMP MALE BULLET	SUPPLIED WITH ENGINE		2
13		M8 RING CRIMP TERMINAL	SUPPLIED WITH ENGINE		1
14	70-0061	RECEPTACLE COVER	RS	1505PVC	7
15	70-0063	BLADE COVER	RS	1504PVC	1
16	70-0058	RECEPTACLE 0.8-2.1mm	TYCO ELECTRONICS	42282-2	10

SHT. 2 OF 2

<p>TCP ELECTRONICS CORPORATION FLORIDA, LTD. ONE WOODLAND AVENUE WOODLAND, ESSEX COUNTY, MA 01890 TEL: 418-621-8077 FAX: 418-621-8330 WWW.TCPEU.COM</p>	<p>TITLE: WIRING LOOM FOR KUBOTA OC95 HLT 500 MK4 - 2006</p>	<p>ISS. A DATE 13.12.2005</p>
<p>DWG No. TCP-1574-01 WL</p>	<p>STK. No. 73-0010</p>	

ITEM	STK. No.	DESCRIPTION	MANUFACTURER	PART No.	QTY
1	---	CRIMP RECEPTACLE - RED	DURITE	0-001-09	2
2	---	CRIMP RECEPTACLE - BLUE	DURITE	0-001-17	4
3	70-0049	TAB HOUSING 2 WAY	TYCO ELECTRONICS	180924-0	1
4	70-0051	TAB HOUSING 2 WAY 'T'	TYCO ELECTRONICS	180908-0	1
5	---	HERSHMAN PLUG	SUPPLIED WITH VALVE	503LT	1
6	70-0060	6.3 IN-LINE RECEPTACLE	RS	1505PVC	4
7	70-0061	RECEPTACLE COVER	RS	180923-0	1
8	70-0048	RECEPTACLE HOUSING 2 WAY	TYCO ELECTRONICS	180923-0	4
9	71-0008	PIEZO SWITCH	SATA	732D4-691	1
10	70-0056	RECEPTACLE 0.3-0.8	TYCO ELECTRONICS	60838-1	2
11	70-0058	RECEPTACLE 0.8-2.1	TYCO ELECTRONICS	42282-2	2
12	70-0059	TAB 0.8-2.1	TYCO ELECTRONICS	42241-2	2
13	71-0007	RELAY 2 POLE C/O 12V COIL	FINDER	67.98.9.012.0003	1

* FITTED ON FINAL ASSY.

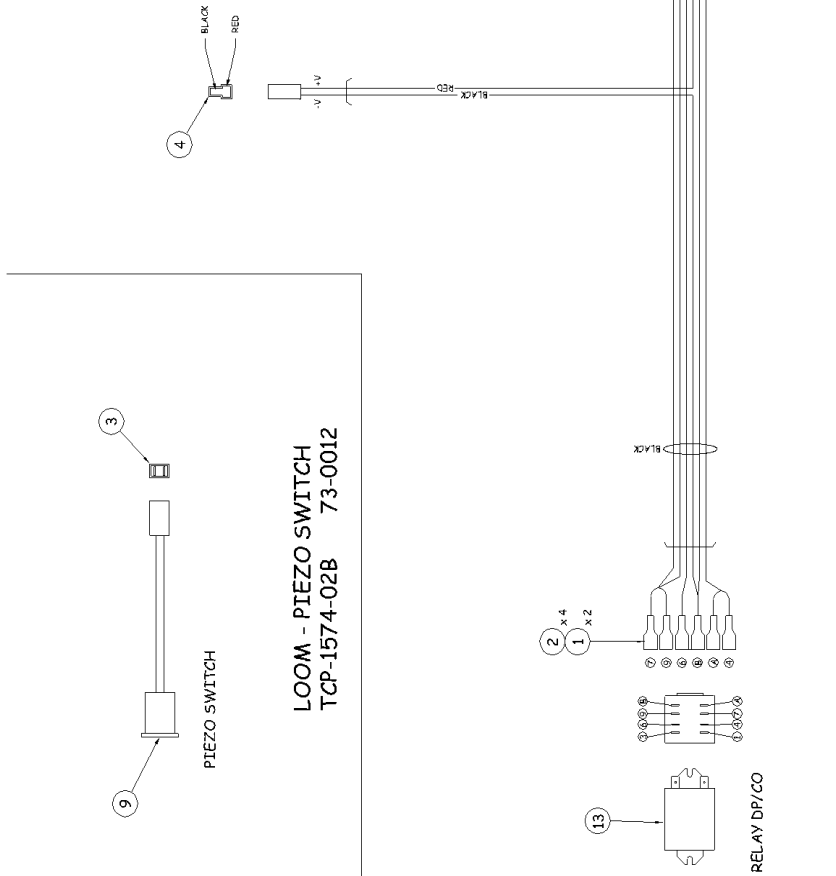

LOOM - TWO SPEED
TCP-1574-02A 73-0011

N.B. 1. ALL CONNECTORS VIEWED FROM WIRING SIDE.
2. SEE CONNECTOR SPEC.
3. USE FLEXIBLE SHRINK WRAP.

TCP-1574-02A WIRING LOOM FOR 2 SPEED
HIT500 MK4 - 2006
TITLE: WIRING LOOM FOR 2 SPEED
HIT500 MK4 - 2006
DWG No. TCP-1574-02 WL
STK. No.

ISS. A
DATE
14.12.2005

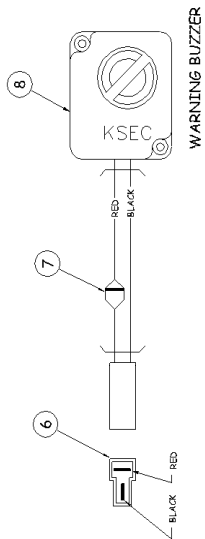

LOOM - BUZZER
TCP-1574-03C 73-0015

ITEM	STK. No.	DESCRIPTION	MANUFACTURER	PART No.	QTY
1	71-0005	RELAY BASE	DURITE	0-725-02	1
2	70-0062	RECEPTACLE HOUSING 3 WAY	TYCO ELECTRONICS	180941-0	1
3	70-0060	6.3 IN-LINE RECEPTACLE	RS	508LT	2
4	70-0061	RECEPTACLE COVER	RS	150PAC	2
5	70-0060	RECEPTACLE HOUSING 2 WAY	TYCO ELECTRONICS	180907-0	1
6	70-0061	TAB HOUSING 2 WAY	TYCO ELECTRONICS	180908-0	2
7	71-0004	UNIDIRECTION TRANSIST DIODE	GENERAL SEMICONDUCTORS	1CTE12	1
8	71-0003	PANEL MOUNT SIREN 102dB	RS	231-2939	1
9	70-0015	PROXIMITY PROBE LEAD 90°	INDUSTRIAL CONTROLS	80400103.W090	1
10	70-0059	TAB HOUSING 3 WAY	TYCO ELECTRONICS	180940-0	1
11	70-0067	TAB 0.3-0.8	TYCO ELECTRONICS	60838-1	3
12	70-0068	RECEPTACLE 0.8-2.1	TYCO ELECTRONICS	42282-2	5
13	70-0069	TAB 0.8-2.1	TYCO ELECTRONICS	42241-2	4
14	71-0006	RELAY 1 POLE 12 V	CARGO	160083	1

N.B. 1. ALL CONNECTORS VIEWED FROM WIRING SIDE.
2. SEE CONNECTOR SPEC.
3. USE FLEXIBLE SHRINK WRAP.

TITLES: WIRING LOOM FOR AUXILIARIES
HIT500 MK4 - 2006
ISS: A
DATE: 14122006

DWG No. TCP-1574-03 WL
STR No.

TRINITY GROUP STRUCTURE PLANT LTD.
QUAYSIDE PARK, BATES ROAD,
MALDON, ESSEX, SAE5 5PA
TEL: 01465 761111 FAX: 01465 761130
WWW.TCP-EL.COM

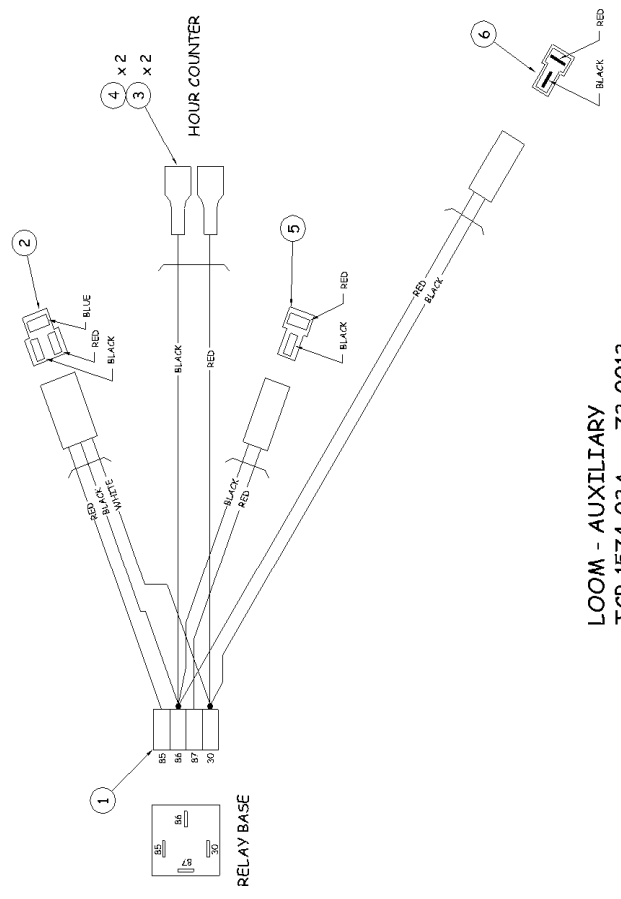

LOOM - AUXILIARY
TCP-1574-03A 73-0013

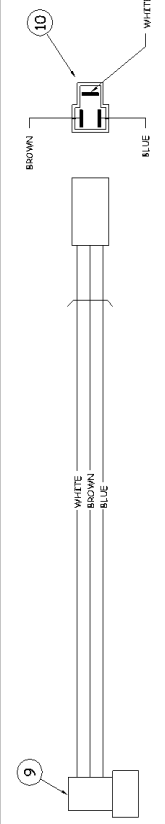

LOOM - PROXIMITY SWITCH
TCP-1574-03B 73-0014

ITEM	STK. No.	DESCRIPTION	MANUFACTURER	PART No.	QTY
1	71-0006	RELAY BASE	EURITE	D-725-02	1
2	70-0004	RECEPTACLE HOUSING 6 WAY(S)	KUBOTA	15662-50830	1
3	70-0005	TAB HOUSING 4 WAY	TYCO ELECTRONICS	180901-0	1
4	70-0006	RECEPTACLE DS-2.1	TYCO ELECTRONICS	42282-2	8
5	70-0009	TAB DS-2.1	TYCO ELECTRONICS	42241-2	3
5	-	CRIMP TERMINAL - RED	EURITE	D-301-09	2

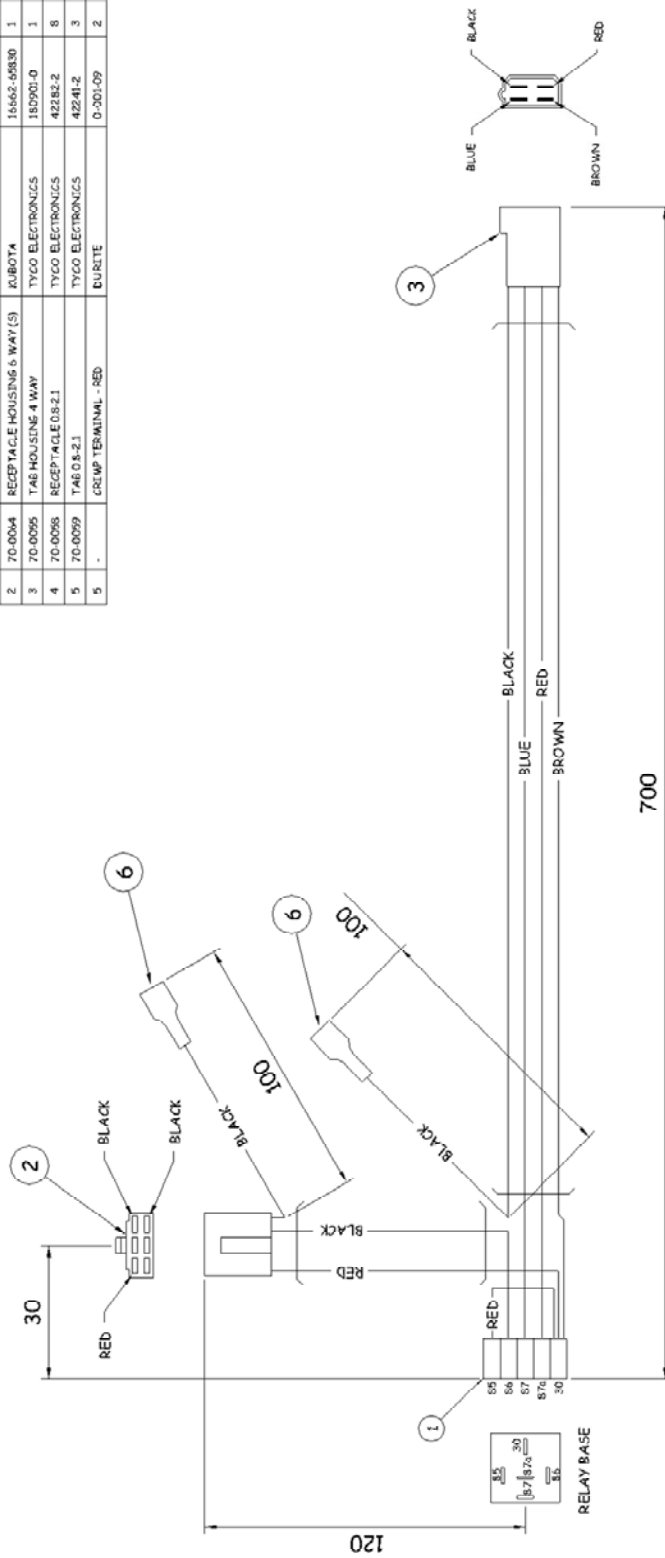

- N.B. 1. ALL CONNECTORS VIEWED FROM WIRING SIDE
2. SEE CONNECTOR SPEC
3. USE FLEXIBLE SHRINK WRAP.

TRAY JOINT CASE DISTRIBUTION PLANT LTD.
CLAYDON PARK, BATES ROAD,
WALSLEY, ESSAY, GAIN SPA,
TEL: 4683300 FAX: 468313330
WWW.TOPJOB.COM

TITLE: WIRING LOOM FOR COLD START
H-T500 MK4 - 2006

DWG No. TCP-1574-C4 WL

ISS. B

DATE 14.12.2006

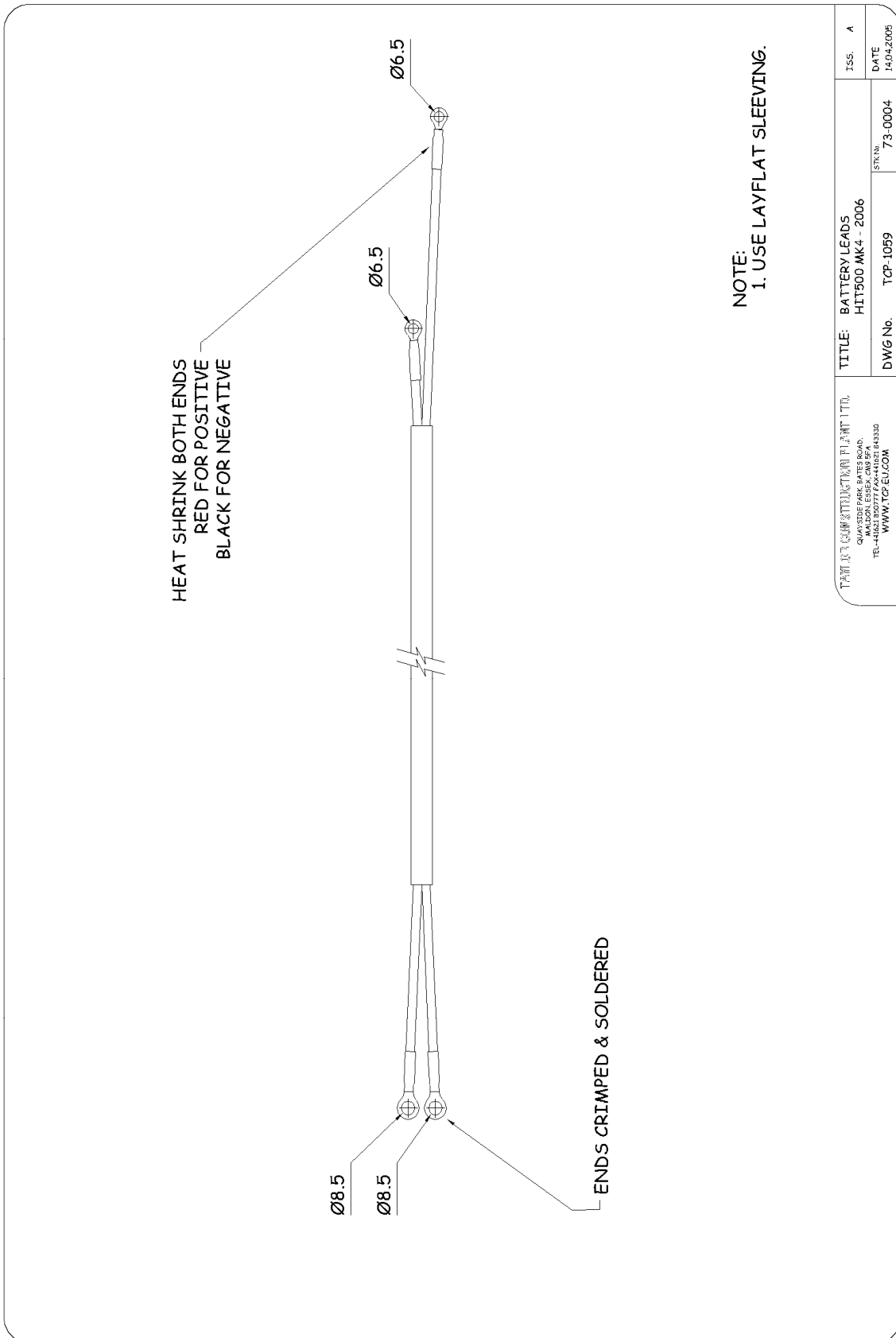

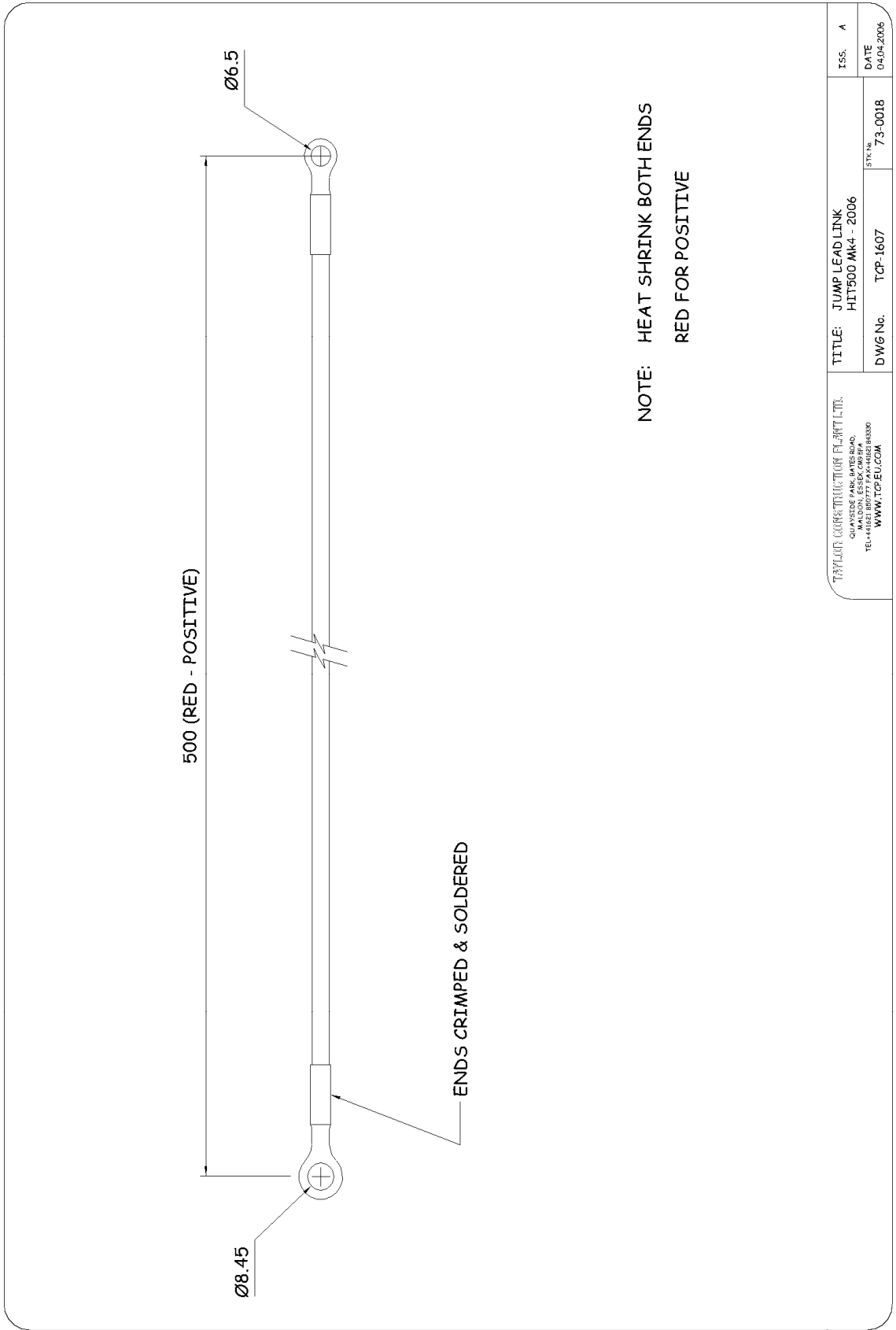

TAYLOR CONSTRUCTION EQUIPMENT LTD. OLYMPIA PARK, BATESDALE, WALTON, ESSEX, CB9 9FA TEL: +44 (0)1206 850300 WWW.TCP.EU.COM		TITLE: JUMP LEAD LINK HIT500 MK4 - 2006	ISS: A
DWG No. TCP-1607		STR No. 73-0018	DATE 04-04-2006

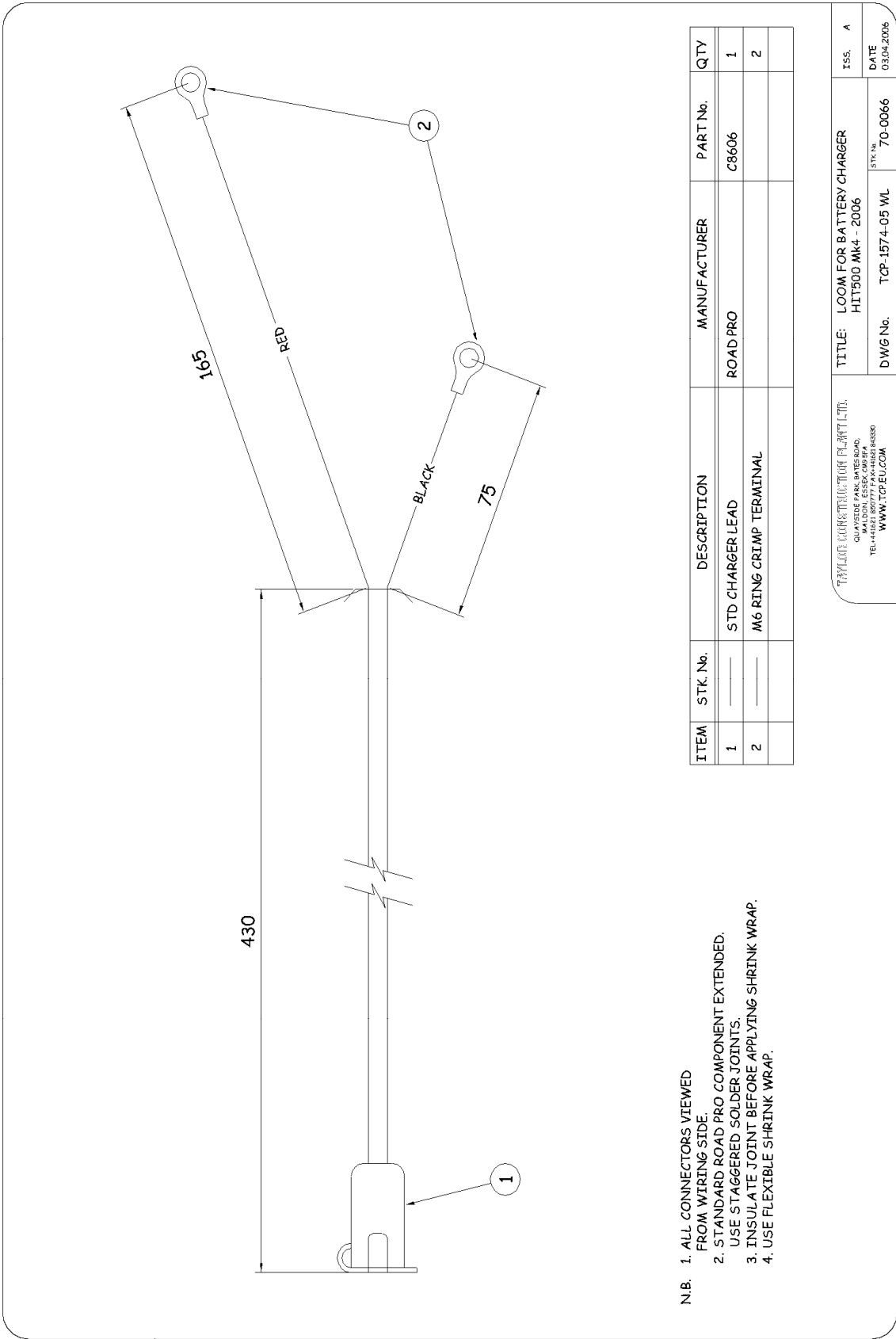

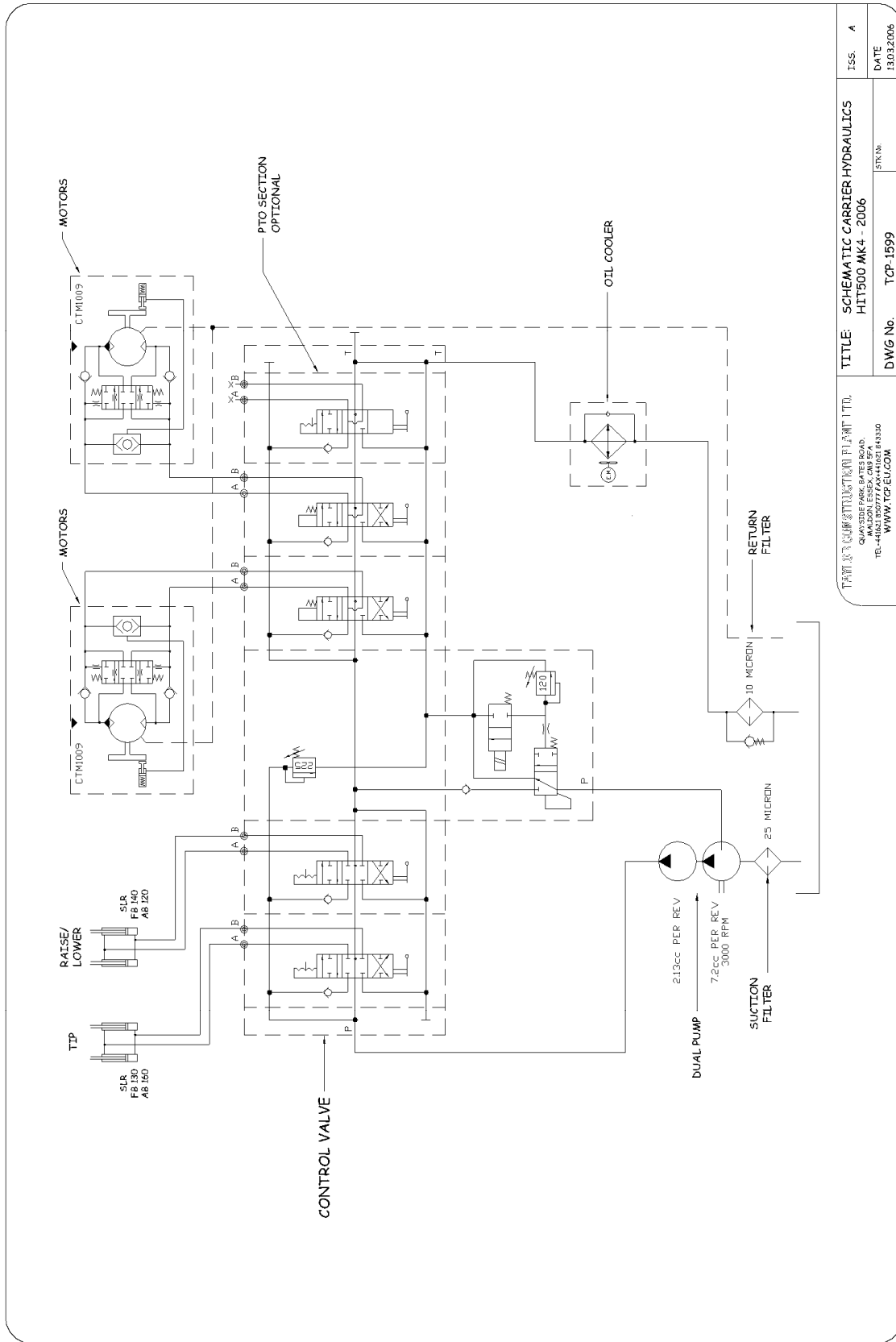

TARIK R. T. CORPORATION PLANT LTD. 601 W. 5TH ST. S.W. SUITE 2000 MALDEN, ILLINOIS 62458 USA TEL: 462/30077 FAX: 462/34330 WWW.TCP.EU.COM		ISS. A DATE 13032006
TITLE: SCHEMATIC CARRIER HYDRAULICS HIT500 MK4 - 2006	DWG No. TCP-1599	STR. No.

Operation - Safety - Maintenance
TCP-1602-01 Issue I

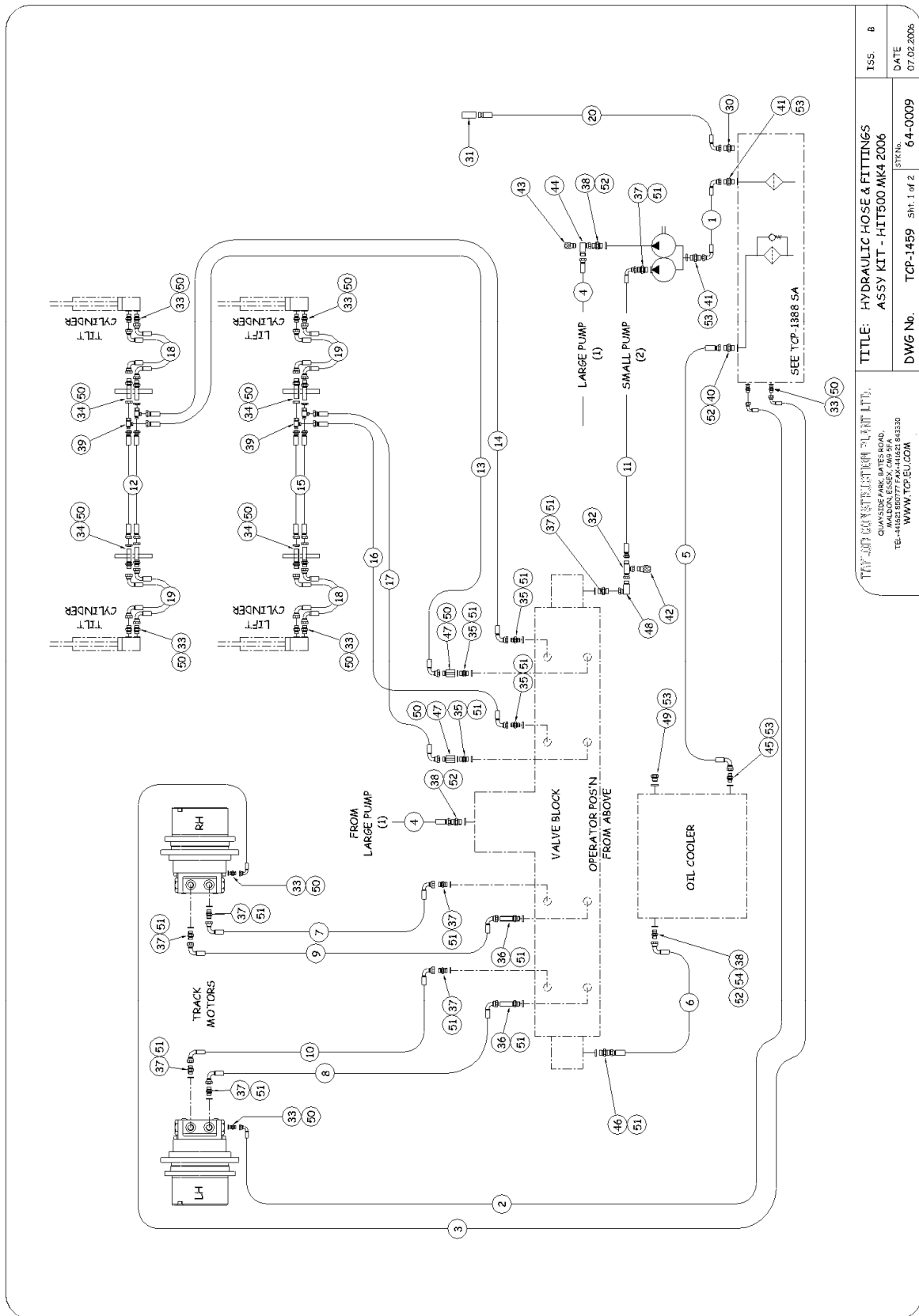

TITLE: HYDRAULIC HOSE & FITTINGS ASSY KIT - HIT500 MK4 2006		ISS. 8
DWG No. TCP-1459 Sht. 1 of 2		DATE 07.02.2006
TCP SUPPLY SYSTEMS LTD. QUAYSIDE PARK, DATES ROAD, TEL: +44 (0) 1452 800777 FAX: +44 (0) 1452 843330 WWW.TCP.EU.COM		STY No. 64-0009

Operation - Safety – Maintenance
TCP-1602-01 Issue I

ITEM	DESCRIPTION	WHERE USED	STK No	QTY
1	¾ 1w 380 Cut Length 90°C-90°S @ 60°	Tank Suction To Pump	62-0090	1
2	¼ 1w 320 Cut Length 90°S-90°C @ 350° (Lefthand Motor)	Drains From Track Motors	62-0091	1
3	¼ 1w 320 Cut Length 90°S-90°C @ 270° (Righthand Motor)	Drains From Track Motors	62-0092	1
4	½ 2w 640 Cut Length FM-FM	Large Pump To Valve Block	62-0034	1
5	5/8 1w 540 Cut Length 90°C-ST Female	Oil cooler to Return Filter	62-0093	1
6	½ 1w 460 Cut Length 90°S-90°C @ 180°	Valve to Oil cooler	62-0094	1
7	3/8 2w 1450 Cut Length 90°S-90°C @ 270°	Righthand Track Motor	62-0095	1
8	3/8 2w 1425 Cut Length 90°S-90°C @ 105°	Lefthand Track Motor	62-0096	1
9	3/8 2w 1350 Cut Length 90°S-90°C @ 290°	Righthand Track Motor	62-0097	1
10	3/8 2w 1350 Cut Length 90°S-90°C @ 115°	Lefthand Track Motor	62-0098	1
11	3/8 2w 680 Cut Length 90°S-Fm	Small Pump To valve	62-0035	1
12	¼ 1w 430 Cut Length 45° B/E @ 0°	Cross Over Top Cylinders	62-0018	2
13	¼ 1w 450 Cut Length 45°-90°S @ 90°	Valve To Cylinder	62-0099	1
14	¼ 1w 450 Cut Length 45°-90°S @ 135°	Valve To Cylinder	62-0120	1
15	¼ 1w 450 Cut Length 45° B/E @ 0°	Cross Over Bottom Cylinders	62-0018	2
16	¼ 1w 740 Cut Length 45°-90°S @ 180°	Valve To Cylinder	62-0121	1
17	¼ 1w 740 Cut Length 45°-90°S @ 180°	Valve To Cylinder	62-0122	1
18	¼ 1w 550 Cut Length 90°S-90°S Opposite To Lay @ 270° Sleeved In Pairs	Chassis To Cylinder	62-0123	2 Prs
19	¼ 1w 550 Cut Length 90°S-90°S Opposite To Lay @ 90° Sleeved In Pairs	Chassis To Cylinder	62-0124	2 Prs
20	½ 1w 550 Cut Length 90°S-Male	Air Breather Extension	62-0125	1
30	1/2 - M22 Male-Male		62-0080	1
31	1/2 - 5/8 Barrel		62-0081	1
32	3/8 Male-Female-Female Tee		62-0082	1
33	1/4 BSP Male-Male		62-0001	10
34	1/4 Extended Bulkhead C/W Nuts		62-0005	8
35	3/8 -1/4 Male-Male		62-0031	4
36	3/8 BSP Male-Male Bulkhead (No Nuts)		62-0083	2
37	3/8 BSP Male-Male		62-0007	8
38	1/2 BSP Male-Male		62-0009	3
39	1/4 BSP Male-Female-Male Swivel Tee		62-0003	4
40	1/2 - 5/8 BSP Male-Male		62-0010	N/R
41	3/4 BSP Male-Male		62-0013	1
42	3/8 BSP Test point		62-0015	1
43	1/8 BSP Test point		62-0084	1
44	1/2 Male-Female Block Elbow (Drilled and Tapped 1/8 BSP 90° to FM)		62-0085	1
45	3/4 - 5/8 BSP Male-Male		62-0086	1
46	3/8 - 1/2 BSP Male-Male		62-0087	1
47	1/4 BSPP - 1/4 BSPP Male-Female Extended		62-0088	2
48	3/8 BSP Male-Female Block Elbow		62-0113	1
49	3/4 Blanking plug		62-0118	1
50	1/4 Bonded Seal		62-0002	20
51	3/8 Bonded Seal		62-0008	16
52	1/2 Bonded Seal		62-0011	3
53	3/4 Bonded Seal		62-0014	3
54	1/2 Copper Seal		62-0089	1

ISS. c	DATE
	07.02.2006
TITLE: HYDRAULIC HOSE & FITTINGS	REV. No.
	64-0009
ASSTY KIT - HIT500 MK4 2006	SH. 2 of 2
	TCP-1459
DWG No.	
DIMENSIONS IN INCHES UNLESS NOTED OTHERWISE. QUANTITY IN PARENTHESES. TEL:41431 82077 FAX:41431 84330 WWW.TCP.EU.COM	

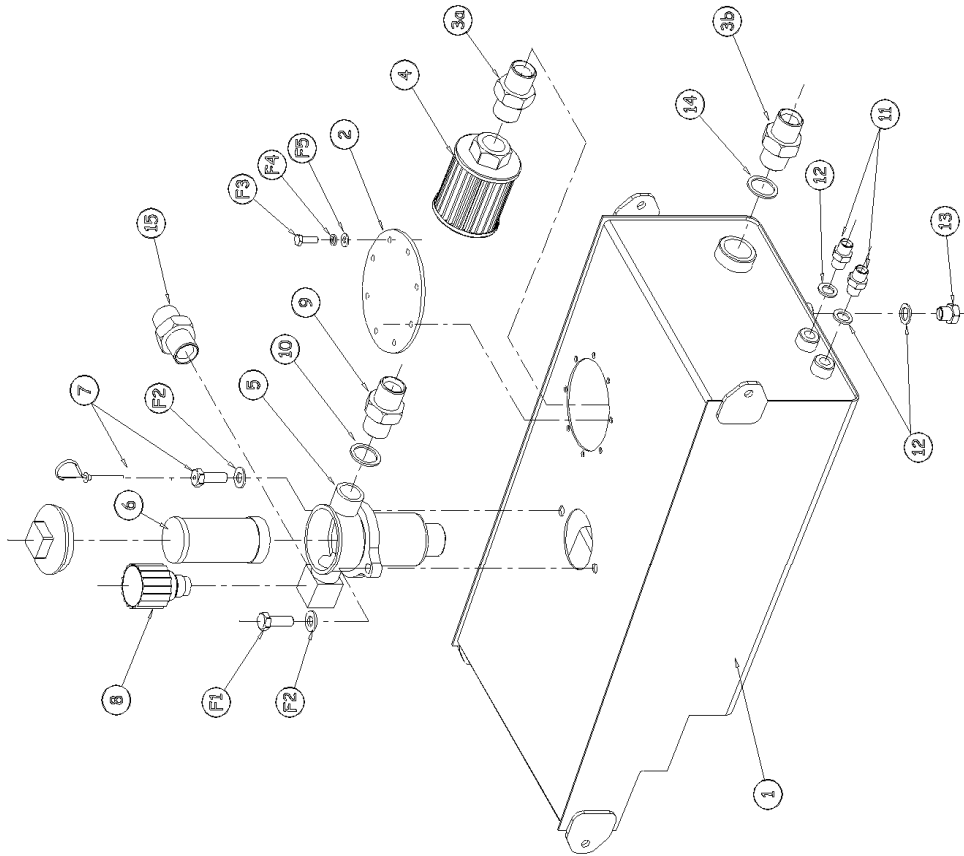

ITEM	DWG No.	PART No.	DESCRIPTION	QTY
1	008	50-0001	TANK	1
2	037	50-0002	COVER, TANK	1
3a		62-0013	3/4" x 3/4" MALE - MALE	1
3b	1459 SA - ITEM 53		3/4" x 3/4" MALE - MALE	1
4		63-0005	SUCTION FILTER	1
5		63-0001	FILTER ASSY C/W CAP	1
6		63-0002	REPLACEMENT CARTRIDGE	-
7		63-0003	DIPSTICK	1
8		63-0004	BREATHER, PRESSURISED	1
9	1459 SA - ITEM 40		1/2 - 5/8 MALE MALE	1
10	1459 SA - ITEM 53		1/2 BONDED WASHER	1
11		62-0001	1/4 - 1/4 MALE MALE	2
12		62-0002	1/4 BONDED WASHER	3
13		62-0004	DRAIN PLUG	1
14		62-0014	3/4 BONDED WASHER	1
15	1459 SA - ITEM 30		1/2 - M22 MALE MALE	1
F1		01-0001	M10 x 35 HEX HD SET SCREW	1
F2		02-0002	M10 WASHER	2
F3		01-0002	M6 x 20 HEX HD SET SCREW	6
F4		02-0003	M6 SPRING WASHER	6
F5		02-0004	M6 WASHER	6

TAYLOR CONSTRUCTION PLANT LTD.
 CHURCHILL ROAD,
 WALTON, ESSEX, CB9 7JY
 TEL: 04651 80777 FAX: 04651 81330
 WWW.TCP.CO.UK

TITLE: HYDRAULIC TANK ASSY
 HET500 MK3 & MK4
 DWG No. TCP-1388 SA
 ITEM: 63-0007
 ISS. A
 DATE 30.01.2006

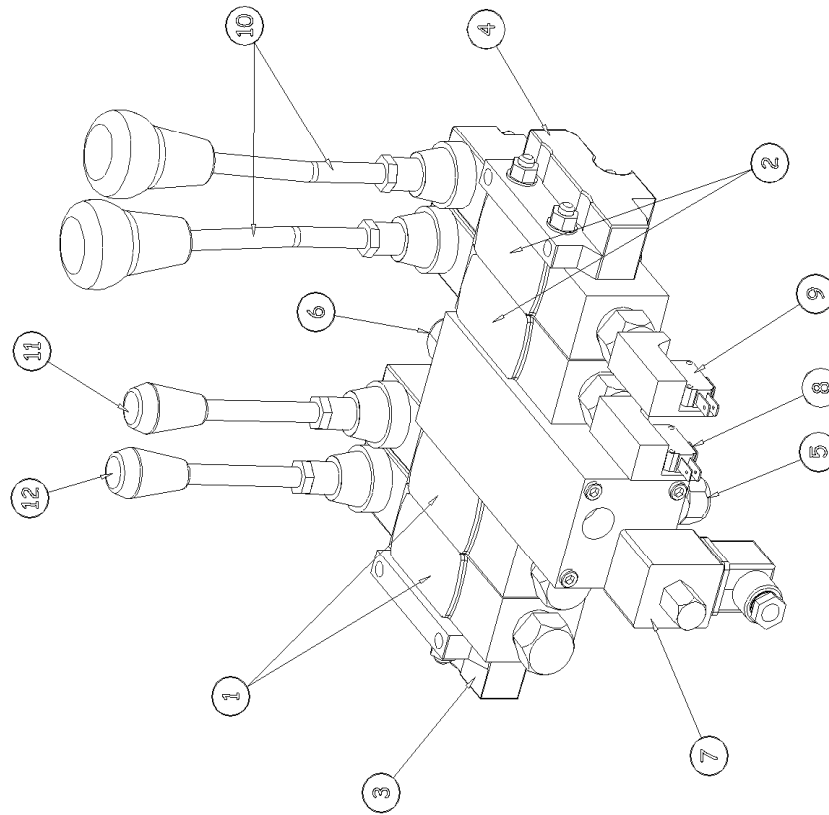

ITEM	DRG No.	PART No.	DESCRIPTION	QTY
1		60-0035	VALVE MODULE COMPLETE - RAMS	2
2		60-0034	VALVE MODULE COMPLETE - TRACKS	2
3		60-0137	END CAP RH	1
4		60-0138	END CAP LH	1
5		60-0012	RELIEF CARTRIDGE	1
6		60-0011	FLOW DIVIDER	1
7		60-0128	COIL MODULE 12V COMPLETE	1
8		72-0003	SWITCH MODULE COMPLETE	2
9		70-0203	MICRO-SWITCH ONLY PER MODULE	1
10		60-0021	CONTROL LEVER - BLACK	2
11		60-0020	CONTROL LEVER - GREEN	1
12		60-0023	CONTROL LEVER - YELLOW	1
13		60-0048	SEAL KIT PER MODULE	1

TAYLOR CONSTRUCTION PLANT LTD. QUAYSIDE PARK, BATES ROAD, HAYDON, DEVON, EX16 9JH TEL: +44 (0)1392 831133 WWW.TCP.EU.COM		TITLE: CONTROL VALVE ASSY MK4 HET800 MK4 - 2006		ISS. 4
DWG No. TCP-1598 SA		STR No. 60-0003		DATE 18.02.2006

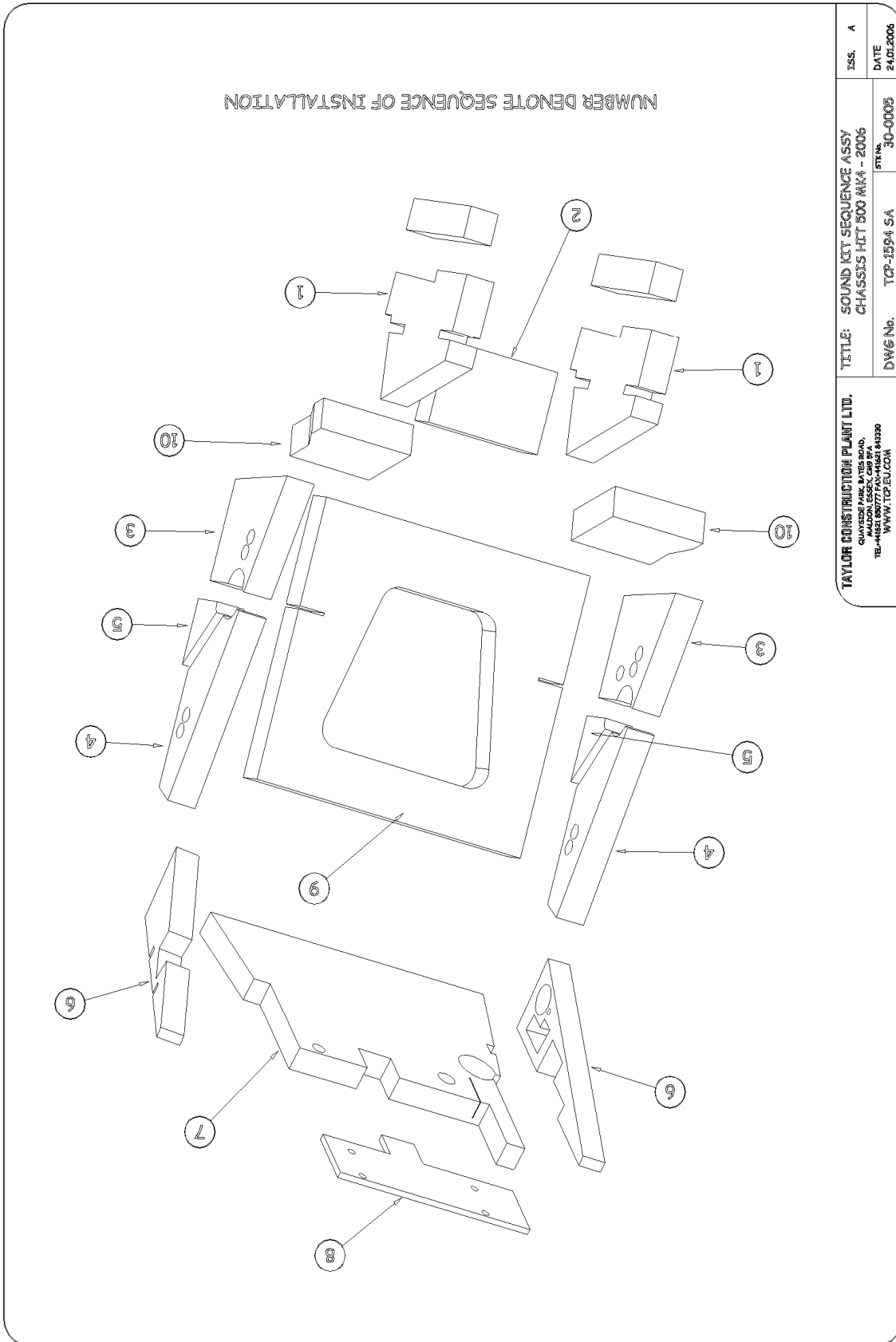

TAYLOR CONSTRUCTION PLANT LTD. QUAYWAYS PARK, BATES ROAD, WALTON, ESSEX, CH47 9PA TEL: +44(0)12077 640140/41/42/43/44 WWW.TCP.EU.COM	TITLE: SOUND KIT SEQUENCE ASSY CHASSIS HLT 500 MK4 - 2006	ISS. A
	DWG No. TCP-1594-SA STR No. 30-0005	DATE 24.01.2006

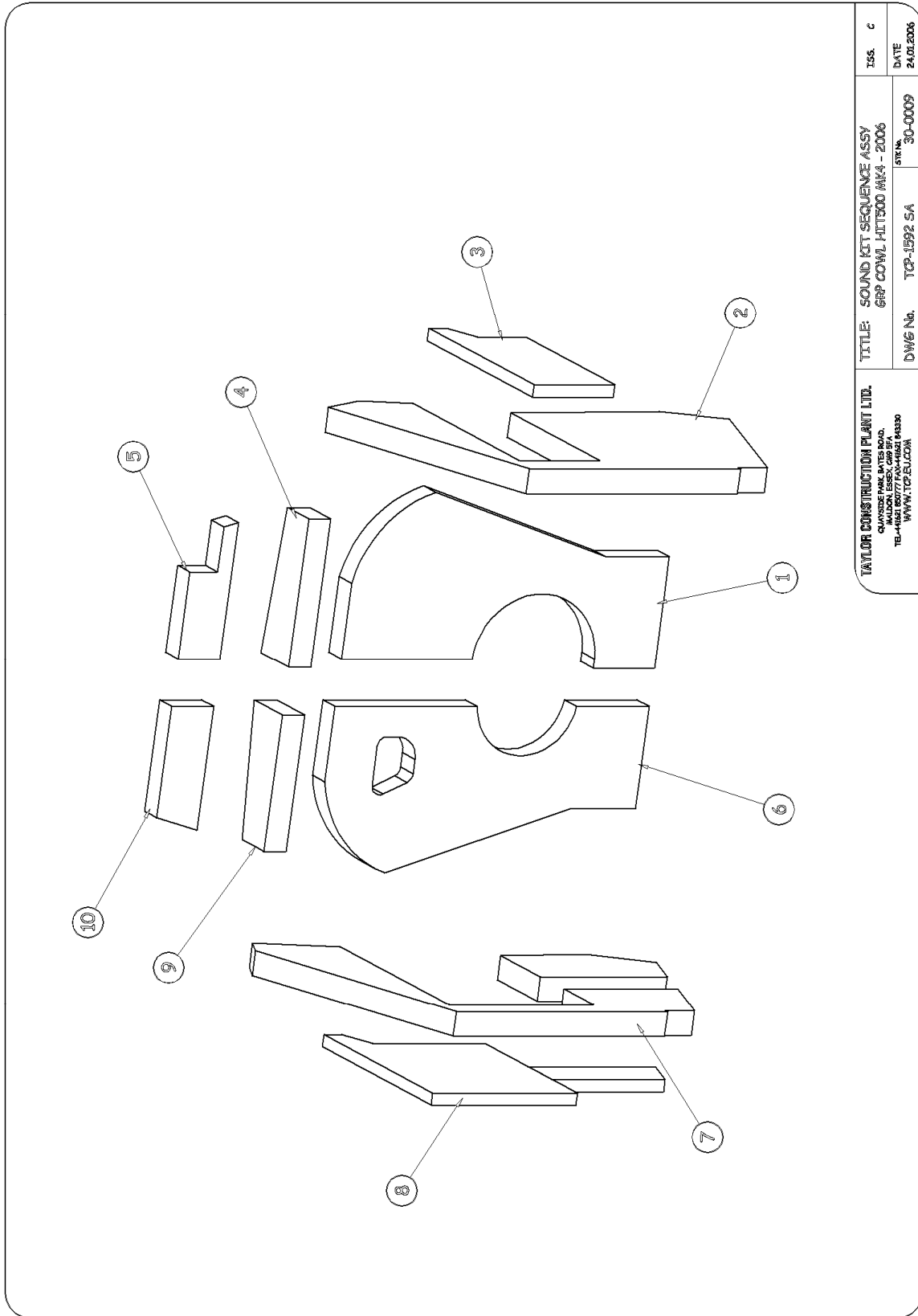

TAYLOR CONSTRUCTION PLANT LTD. CHANDLER PAC BATES ROAD, TEL: +61 8 85177 FAX: +61 8 8330 WWW.TCP.SA.COM	TITLE: SOUND KIT SEQUENCE ASSY GRP COWL HIT1500 MK4 - 2006	ISS. C
DWG No. TCP-1592 SA	SIX No. 30-0009	DATE 24.01.2006

NOTES: